

Wi-LEM

Wireless Local Energy Meter

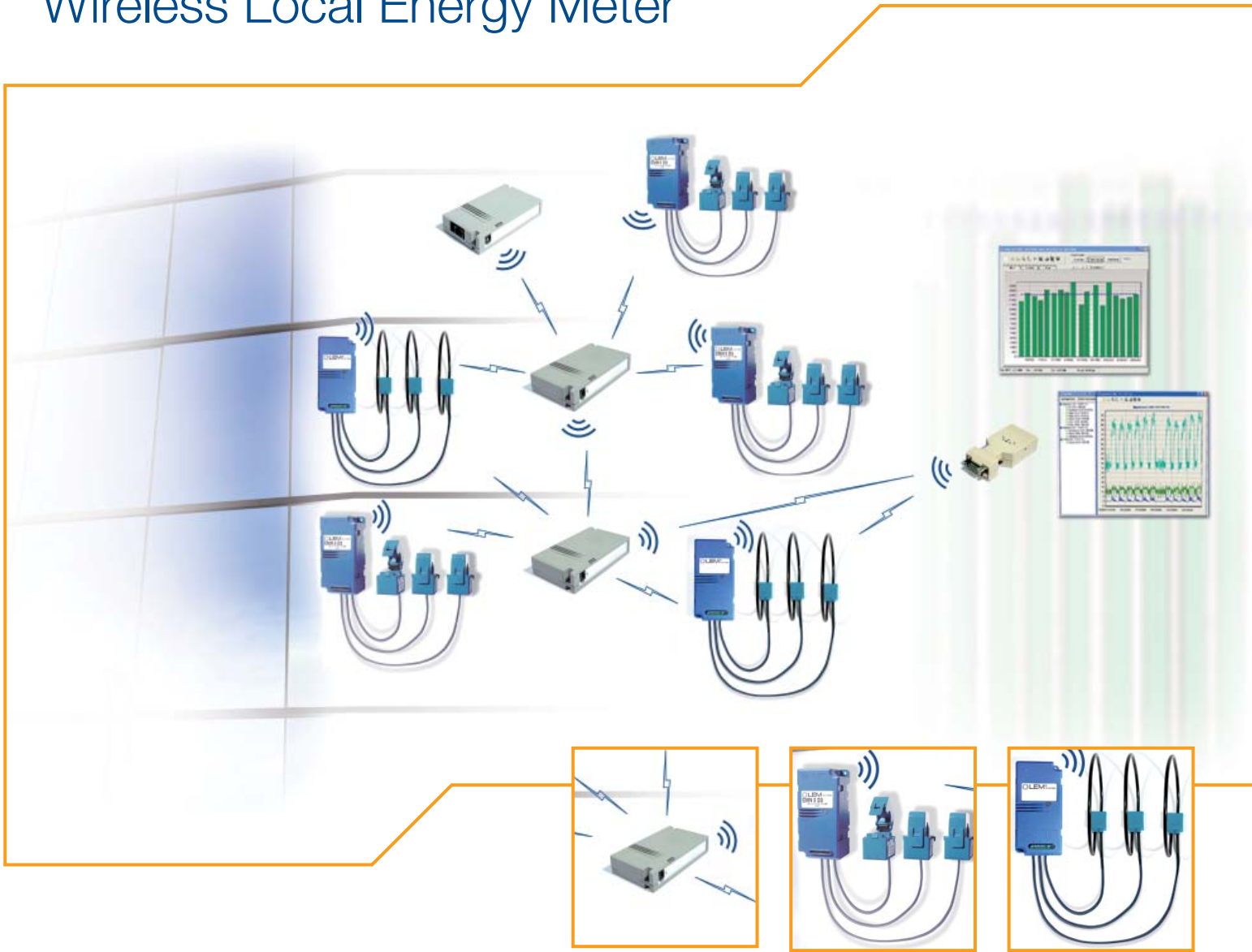

I. IDENTIFICATION

I.1 DOCUMENT

Wireless Local Energy Meter (Wi-LEM) User Guide

Document version	Date	Evolution
V0	2007.03.16	Creation
V1	2007.09.28	Minor corrections
V2	2009.04.22	Add new EMN types built with Rogowski coils, Mesh Gate & MeshNode Long Range & Extra Long Range, Mesh Node-6424 (without antenna), Wi-Pulse, Wi-Zone. Add a network commissioning chapter.
V3	2009.07.02	Modification on pages 5.3, 5.4, 5.5
V4	2010.05.17	Add appendix for MG 6424 and Wi-temp information
V5	2010.08.06	Modification on page 3.10 (replaced Caution by Warning paragraph + add note for Fig. 3-16)
V6	2011.03.10	Remove previous MG 5424 model. Add information for MG 6424 in RS 485 mode.
V7	2011.12.12	Add CE Marking information § 1.1 on page 1-1. Modification second sentence § 4.2.4 on page 4-4

I.2 MANUFACTURER

LEM SA

Chemin des Aulx 8

CH - 1228 Plan-Les-Ouates

Geneva, Switzerland

Tel. +41 (0)22 706 11 11

Fax +41 (0)22 706 94 78

Copyright ©

The reproduction, even partially, of this document is forbidden. No part may be copied in any form, and it may not be used, edited nor transmitted by any electronic means (photocopy, photography, magnetic supports or other recording processes), without the written authorization of LEM SA. All rights and particularly reproduction, translation, edition, distribution and also industrial property and recording are reserved.

Printed in Switzerland

TABLE OF CONTENTS

1	NOTICE	1-1
1.1	Certification directives related to EMN	1-1
1.2	Safety instructions.....	1-2
1.2.1	Introduction	1-2
1.2.1.1	Principle	1-2
1.2.1.2	Importance of safety indications	1-2
1.2.1.3	Failure to respect safety regulations	1-2
1.2.2	General rules for all users.....	1-2
1.2.3	User guide	1-3
1.2.4	Differentiation of degrees of risk	1-3
1.2.4.1	General risks	1-3
1.2.4.2	Electric cabinet or live components	1-3
2.	WI-LEM AND NETWORK DESCRIPTION	2-1
2.1	About the Wi-LEM	2-1
2.2	EMN.....	2-3
2.2.1	Detailed Description	2-3
2.2.2	Models Description.....	2-4
2.2.3	Main Characteristics	2-6
2.2.3.1	EMN Line powered up to 300 V	2-6
2.2.3.2	EMN External power (SP2 model and other)	2-6
2.3	Mesh Gate MG 6424 description	2-7
2.4	Mesh Node description	2-8
2.5	Network.....	2-9
2.5.1	Network Characteristics	2-9
2.5.2	Introduction	2-10
2.5.3	Description	2-10
3.	HARDWARE INSTALLATION AND CONTROL	3-1
3.1	Important warning and notices.....	3-1
3.2	Before You Start.....	3-1
3.3	Network deployment recommendations	3-2
3.3.1	Basic guidelines	3-2
3.3.1.1	Building audit.....	3-2
3.3.1.2	Walls and floors	3-2
3.3.1.3	Different materials	3-2
3.3.2	Network topologies.....	3-3
3.3.2.1	Best Case Scenario (Star-Mesh topology).....	3-3
3.3.2.2	Worst Case Scenario (Data Bottle Neck)	3-3
3.3.3	EMN location.....	3-4
3.3.3.1	Basic guidelines	3-4
3.3.3.2	Inside a metallic cabinet	3-4
3.3.4	Mesh Gate location and connection	3-4

3.3.5	Mesh Node location and connection	3-5
3.4	Energy Meter Node Mounting.....	3-6
3.4.1	Wall and panel Mounting	3-6
3.4.2	DIN Rail Mounting	3-6
3.4.3	Current sensors mounting	3-7
3.4.3.1	Current Transformer	3-7
3.4.3.2	Rogowski coil	3-8
3.4.4	Voltage Input connection.....	3-9
3.4.4.1	Line powered EMN	3-9
3.4.4.2	24 V DC powered EMN (SP2 models).....	3-10
3.4.5.	LED indicator description	3-11
3.5	Network commissioning.....	3-12
3.5.1	Modules Identification	3-12
3.5.2	Mesh Gate connection.....	3-13
3.5.2.1	Mode selection.....	3-13
3.5.2.2	RS 232 data port use and configuration	3-13
3.5.2.3	RS 485 data port use and configuration	3-14
3.5.3	MeshScape Monitor.....	3-15
3.5.3.1	Network Initialisation and control.....	3-15
4.	SOFTWARE INTERFACE	4-1
4.1	Introduction.....	4-1
4.2	Energy Meter Node.....	4-1
4.2.1	Modbus Register Table.....	4-1
4.2.2	Scaling factors	4-3
4.2.3	Energy counters (register 0 to 26)	4-4
4.2.4	Recording Interval based energy (register 28 to 48)	4-4
4.2.5	Recording Interval Time (register 53)	4-4
4.2.6	Time-stamp	4-6
4.2.7	Frequency (register 27)	4-6
4.2.8	Maximum Current (register 43 to 45).....	4-6
4.2.9	Minimum Voltage (register 46 to 48).....	4-6
4.2.10	Model Configuration (register 49).....	4-6
4.2.11	Software Version (register 50).....	4-7
4.2.12	Status Word (register 51)	4-8
4.2.13	Command Word (register 52).....	4-8
4.2.14	Zero Power Detection (register 70)	4-9
4.2.15	Hop count (register 201)	4-9
4.2.16	RSSI (register 204).....	4-9
4.2.17	Device & Group ID.....	4-10
4.2.18	Network Channel.....	4-10
4.2.19	Sampling Interval	4-10
4.3	Mesh Gate.....	4-11
4.3.1	MG 6424 Register table	4-11
4.3.2	MG 6424 Network Channel modification	4-12
4.3.3	Setting of Mesh Gate Network Time	4-12
4.4	Network.....	4-12
4.4.1	Modbus Interface.....	4-12

4.4.1.1	Mesh Gate Modbus slave	4-12
4.4.1.2	EMN Modbus slave	4-13
4.4.2	Network Identification of EMN	4-13
4.4.3	Modbus Communication	4-14
4.4.3.1	Read Holding Registers (Function code 0x03)	4-14
4.4.3.2	Examples	4-14
4.5	Software utilities	4-15
4.5.1	Addressing a Node.....	4-15
4.5.2	Managing several Mesh networks.....	4-15
4.5.3	Channel choice.....	4-15
4.5.4	Node Device ID & Group ID change.....	4-16
4.5.5	MG 6424 Reprogramming Group ID, Device ID and Channel.....	4-17
4.5.6	Broadcast and Sampling Interval	4-18
4.5.6.1	Introduction	4-18
4.5.6.2	Reprogramming procedure.....	4-19
5.	COMPLEMENTARY PRODUCTS	5-1
5.1	Wi-Pulse	5-2
5.1.1	Description	5-2
5.1.2	Modbus Register Table.....	5-3
5.2	Wi-Zone	5-4
5.2.1	Description	5-4
5.3	Wi-Temp	5-6
5.3.1	Description	5-6
5.3.2	Modbus Register Table.....	5-7
6.	TROUBLESHOOTING	6-1
7.	EMN SOFTWARE RELEASE NOTE.....	7-1
8.	GLOSSARY AND SYMBOLS	8-1

1 NOTICE

1.1 Certification directives related to EMN

The present product is designed to fully agree with the following directives:

CE, FCC, IC

- Federal Communication Commission Interference Statement

This equipment has been tested and found to comply with the limits for a Class B digital device, pursuant to Part 15 of the FCC Rules. These limits are designed to provide reasonable protection against harmful interference in a residential installation. This equipment generates, uses and can radiate radio frequency energy and, if not installed and used in accordance with the instructions, may cause harmful interference to radio communications. However, there is no guarantee that interference will not occur in a particular installation. If this equipment does cause harmful interference to radio or television reception, which can be determined by turning the equipment off and on, the user is encouraged to try to correct the interference by one of the following measures:

- Reorient or relocate the receiving antenna.
- Increase the separation between the equipment and receiver.
- Connect the equipment into an outlet on a circuit different from that to which the receiver is connected.
- Consult the dealer or an experienced radio/TV technician for help.

FCC Caution: Any changes or modifications not expressly approved by the party responsible for compliance could void the user's authority to operate this equipment. (15.21)

This device complies with Part 15 of the FCC Rules. Operation is subject to the following two conditions: (1) This device may not cause harmful interference, and (2) this device must accept any interference received, including interference that may cause undesired operation. (15.19)

IMPORTANT NOTE:

FCC Radiation Exposure Statement:

This equipment complies with FCC radiation exposure limits set forth for an uncontrolled environment. This equipment should be installed and operated with minimum distance 20cm between the radiator & your body.

This transmitter must not be co-located or operating in conjunction with any other antenna or transmitter.

- Industry Canada statement:

This device complies with RSS-210 of the Industry Canada Rules. Operation is subject to the following two conditions:

(1) This device may not cause harmful interference, and (2) this device must accept any interference received, including interference that may cause undesired operation.

IMPORTANT NOTE:

Radiation Exposure Statement:

This equipment complies with IC radiation exposure limits set forth for an uncontrolled environment. This equipment should be installed and operated with minimum distance 20cm between the radiator & your body.

- CE statement: 

The present product is in accordance with the requirement of the R&TTE directive for the following authorized countries: **AT BE BG CH CY CZ DE DK EE ES FI FR GB GR HU IE IS IT LI LT LU LV MT NL PL PT RO SE SI SK TR BA GE HR MD ME MK RS**

Because of restrictions stated in the ERC recommendation 70-03, the following countries are not authorized: **NO RU UA**



For more information, contact LEM's customer service.

1.2 Safety instructions

1.2.1 Introduction

1.2.1.1 Principle

The user must have read and understood this chapter before undertaking any action with / in the system.

For all information considered inadequate, please contact the manufacturer or your local representative.

⚠ CAUTION FAILURE TO FOLLOW THESE INSTRUCTIONS MAY CAUSE SERIOUS ACCIDENTS !

All device users, such as:

- owners;
- installers, maintenance and service personnel, or any other person in related job functions;
- managers, operators, setters, programmers, foremen, mechanics;

must read and strictly follow the safety instructions in this document.

These regulations also pertain to options, components, installations, devices and systems related to the machine.

1.2.1.2 Importance of safety indications

All the safety and protection instructions given in this manual must be respected to prevent reversible or irreversible bodily injuries, material damages or environmental pollution. Similarly, legal regulations, accident prevention and environment protection measures, as well as recognized technical regulations, aimed at appropriate risk-free work methods in force in the country and in the machine workspace must be respected.

1.2.1.3 Failure to respect safety regulations

Any non-respect of the safety and protection rules, as well as existing legal and technical regulations, could cause reversible or irreversible bodily injuries, material damages or environmental pollution.

1.2.2 General rules for all users

⚠ WARNING READ AND FOLLOW THE USER INSTRUCTIONS AND MANUALS DELIVERED WITH THIS SYSTEM. ONLY PEOPLE TRAINED FOR MANIPULATIONS AND ACQUAINTED WITH THESE INSTRUCTIONS CAN WORK ON THE DEVICE.

1.2.3 User guide

- User instructions and user guide delivered by the manufacturer with the system or at a later date must be brought to the attention of all people operating on the device or responsible for it in any way;
- These people must read and strictly follow the user instructions and manuals;
- After the reception of updates, if any, the user will update the documentation.
- Anyone likely to work on the device must have access to the user instructions and manuals.

⚠ CAUTION DOCUMENT TO BE KEPT TO REFER TO IT LATER ON.

1.2.4 Differentiation of degrees of risk

1.2.4.1 General risks

⚠ DANGER WARNS AGAINST A DIRECT DANGER OF DEATH OR SERIOUS INJURY.

⚠ CAUTION INDICATES INCORRECT ACTIONS WHICH MAY CAUSE MINOR HUMAN INJURY OR MAJOR MATERIAL DAMAGE TO THE SYSTEM AND ENVIRONMENT.

⚠ WARNING FOR INFORMATION, INDICATES HANDLING ERRORS OR NEGLIGENCE WHICH MAY CAUSE MATERIAL DAMAGE ON THE DEVICE.

1.2.4.2 Electric cabinet or live components

⚠ DANGER ONLY A QUALIFIED PERSON IS AUTHORIZED TO INTERVENE INSIDE THE ELECTRIC CABINETS OR ON A LIVE COMPONENT.

This page is intentionally left blank

2. WI-LEM AND NETWORK DESCRIPTION

2.1 About the Wi-LEM

The Wi-LEM is a complete data acquisition platform to measure and transmit electrical parameters used for Energy Management application. As it is an open architecture, this platform can be easily interfaced with existing data logger and energy monitoring software.

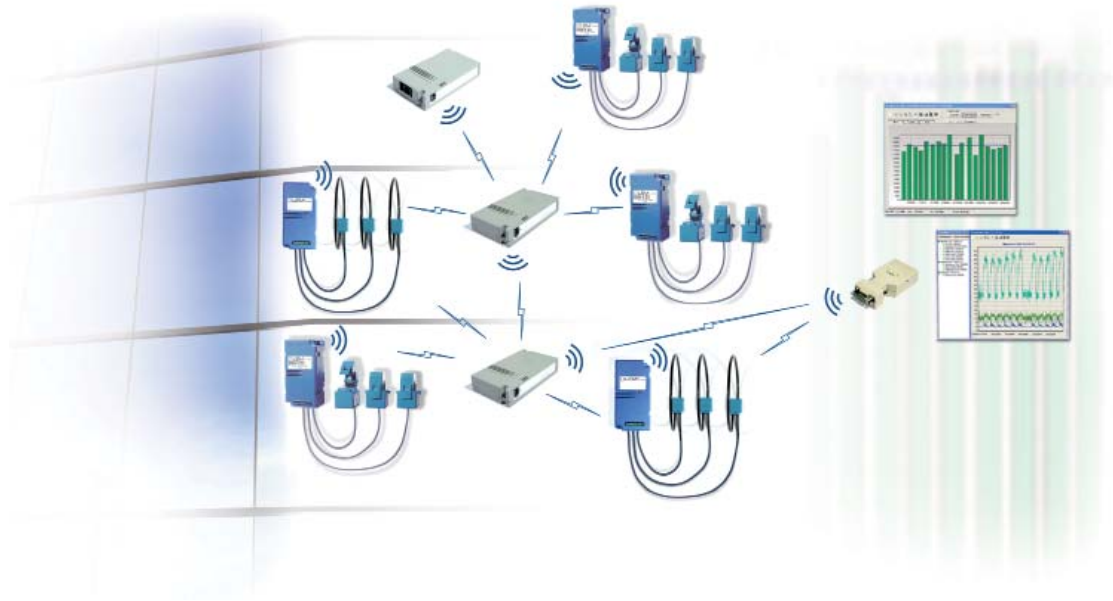

Fig. 2-1: Principle of Wireless Local Energy Meter (Wi-LEM)

The Wi-LEM is constituted by 3 mains parts:

- **Energy Meter Node (EMN):** sub-meter which calculates several electrical parameters with pre-wired split core current transformers or Rogowski coils and embedded wireless data transmission (for more information, see next page).

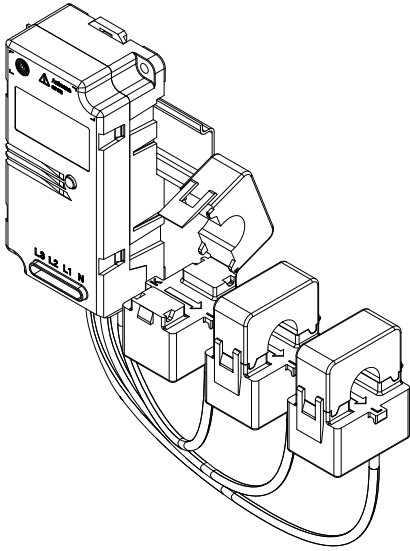

Fig. 2-2: Energy Meter Node with Current Transformers (CT)

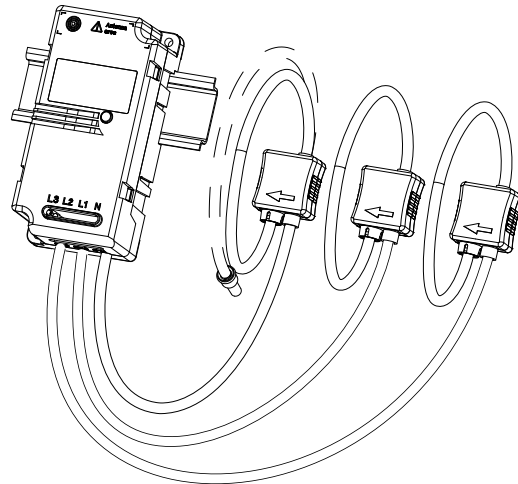

Fig. 2-3: Energy Meter Node with Rogowski Coil transducers (RT)

- **Mesh Gate (MG):** stand alone gateway which manages the wireless network and collects the data periodically sent by the EMN. The MG can be accessed by the data logging system for analysis.



Fig. 2-4: Mesh Gate

- **Mesh Node (MN):** repeater extending the distance of the transmission between the EMN and the MG when needed.

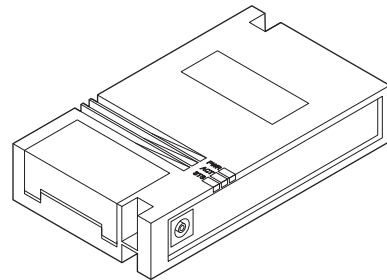

Fig. 2-5: Mesh Node

2.2 EMN

The Energy Meter Node (EMN) is a 3-phase electric meter with a wireless (radio) communication.

1. Led indicator



For more information about the LED indicator, see chapter 3.4.5.

2. Antenna location
3. Clipping fixture for DIN Rail
4. Identification label (ID)
5. Current Transformer (CT) or Rogowski coil (RT)
6. Voltage input

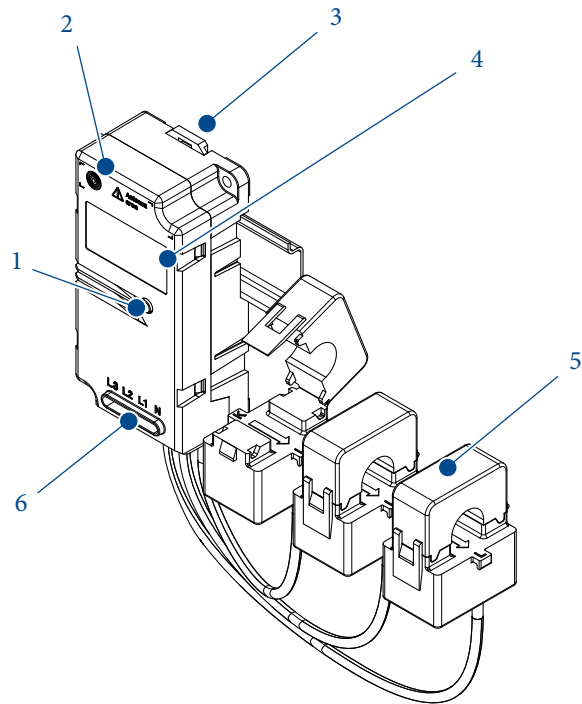

Fig. 2-6: Energy Meter Node built with CT

2.2.1 Detailed Description

Data from the meter is sent to the gateway for user access periodically.

The meter data is split into three sections:

- **Energy Meter:** Active, reactive and apparent energy per phase and sum with a time-stamp.
- **Recording Interval Meter:** Active, reactive and apparent energy per phase and sum with a time-stamp of the end of the recording interval; minimum voltage per phase and maximum current per phase during recording interval; frequency
- **Meter Identification and Configuration:** Meter configuration and version; recording interval time setup, command and status word.

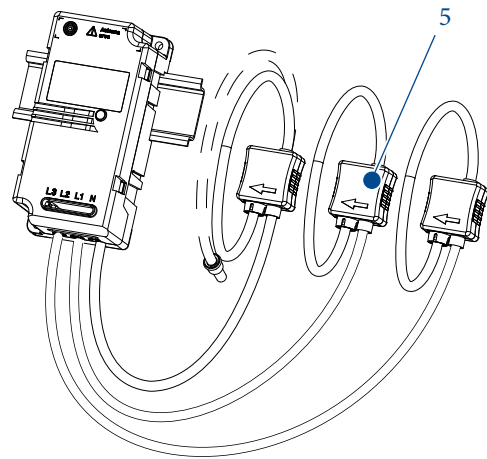
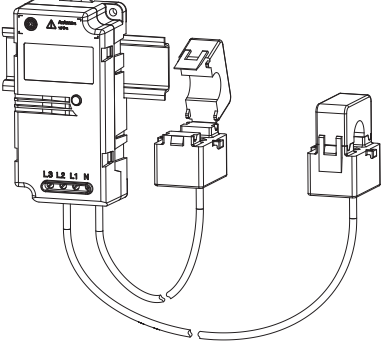
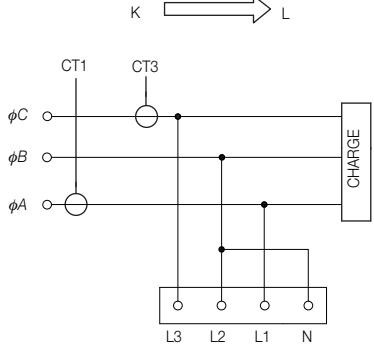
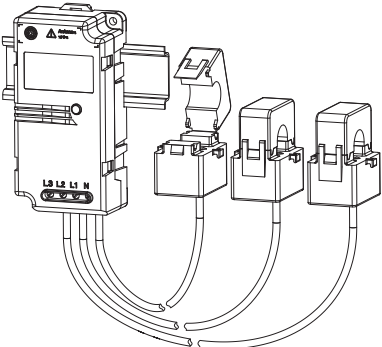
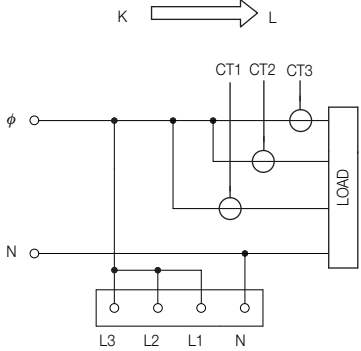
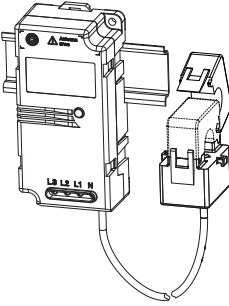
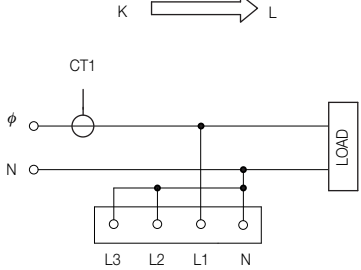

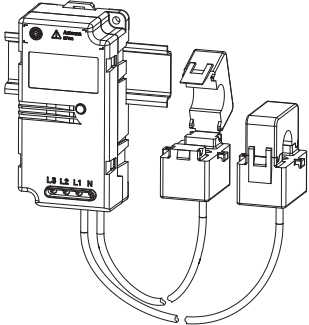

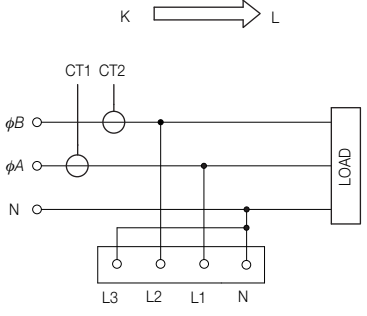
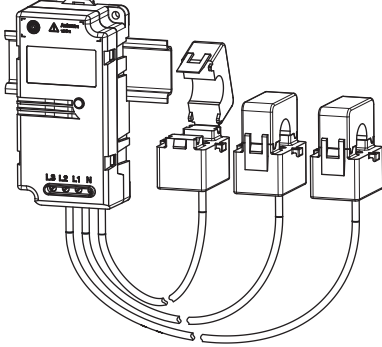

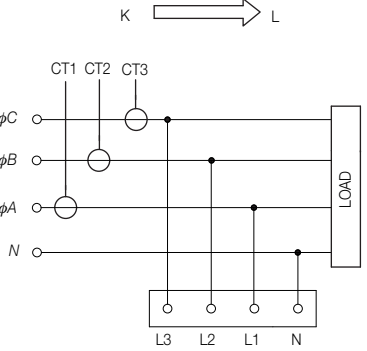
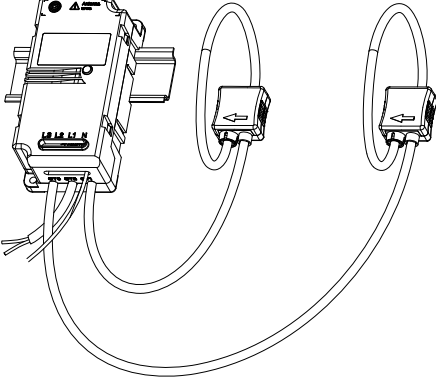



Fig. 2-7: Energy Meter Node built with RT

2.2.2 Models Description

The following table lists the different models of Energy Meter Node available.

Table 2-1: Model Description

Model*	Wiring Diagram (CT and RT)
<p>EMNxxxD3 (Delta - 3 wires) Code: 111</p>  <p>As the maximum voltage is $300 V_{rms}$, this model can not be used on 400 or $480 V_{rms}$ Delta Network.</p> <p>V_{BA} and $V_{BC} \leq 300 V_{rms}$</p>	
<p>EMNxxxW0 (3 single phases on same voltage) Code: 101</p>  <p>$V_{N\phi} \leq 300 V_{rms}$</p>	
<p>EMNxxxW2 (Single phase - 2 wires) Code: 010</p>  <p>$V_{N\phi} \leq 300 V_{rms}$</p>	

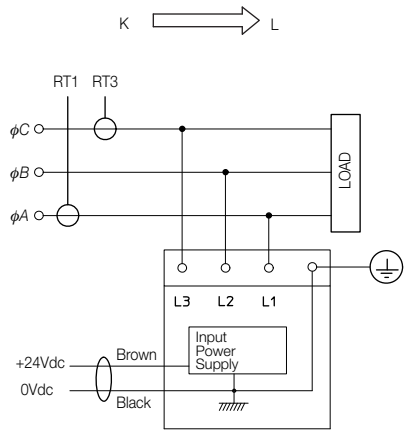
Model*	Wiring Diagram (CT and RT)
<p>EMNxxxW3 (Wye - 3 wires) Code: 011</p>  <p> V_{NA} and $V_{NB} \leq 300 V_{rms}$</p>	 <p>V_{NA} and $V_{NB} \leq 300 V_{rms}$</p>
<p>EMNxxxW4 (Wye - 4 wires) Code: 000</p>  <p> V_{NA}, V_{NB} and $V_{NC} \leq 300 V_{rms}$</p>	 <p>V_{NA}, V_{NB} and $V_{NC} \leq 300 V_{rms}$</p>
<p>EMNxxx-D3/SP2 (Delta - 3 wires) Code: 111</p>  <p> This specific model has been developed for up to $520 V_{rms}$ Delta Network</p> <p> V_{BA} and $V_{BC} \leq 520 V_{rms}$ $V_{A,B,C} - \text{earth} \leq 300 V_{rms}$</p> <p> This device being Isolation Class 1, it must be connected to Earth/Ground (use Green/Yellow wire)</p>	 <p>V_{BA} and $V_{BC} \leq 520 V_{rms}$ $V_{A,B,C} - \text{earth} \leq 300 V_{rms}$</p> <p>This device being Isolation Class 1, it must be connected to Earth/Ground (use Green/Yellow wire)</p>

* for more information about model names, see chapter 4.2.10 "Model configuration"

2.2.3 Main Characteristics

2.2.3.1 EMN Line powered up to 300 V

• Primary Nominal Current:.....	20 A .. 2000 A (according to the model)
• Primary Voltage, Measuring Range (neutral/phase) (V_{PN}) ⁽¹⁾ :	90 to 300 V_{rms}
• Primary Voltage , Nominal Range (N/L) (V_{PN}):....	100 to 272 V_{rms}
• Absolute Min/Max input voltage (N/L):	90 to 300 V_{rms}
• Frequency (f):.....	50 / 60 Hz
• Maximum power consumption	2 W
• Maximum supply current (N-L1)	0.2 A _{rms}
• Ambient operating temperature (90% rH) (T_A) ...	-10 .. + 55°C
• For indoor use only	
• Altitude.....	Up to 2000 m
• Protection degree.....	IP2X
• Pollution degree.....	PD2
• Isolation	 Isolation class II IEC 61010-1 CAT III 300 V_{rms}

2.2.3.2 EMN External power (SP2 model and other)

• Primary Nominal Current (I_{PN}):	100 A .. 2000 A (according to the model)
• Primary Voltage, Measuring Range (V_{PN}):	180 to 520 V_{rms}
• Frequency (f):.....	50 / 60 Hz
• External power supply (+/- 10%) ²⁾	24 V DC
• Maximum supply current	50 mA DC
• Ambient operating temperature (90% rH) (T_A) ...	-10 .. + 55°C
• For indoor use only	
• Altitude.....	up to 2000 m
• Protection degree.....	IP2X
• Pollution degree.....	PD2
• Isolation	Isolation class I IEC 61010-1 CAT III 300 V_{rms}  Product must be connected to earth (ground)



For more details about technical characteristics, refer to the datasheets about the EMN series.

1) Maximum voltage limited to 265 V_{rms} for EMN built with firmware V1.xx

2) Must comply with limited-energy circuit criteria and SELV conditions.

2.3 Mesh Gate MG 6424 description

This product is available in 2 versions:

- Long Range (L) with RF power max. 10 mW
- Extra Long Range (XL) with RF power max.100 mW

1. LED indicators (see table hereunder)
2. Power supply 6 .. 30 V DC
3. RS 232/485 connector
4. Internal Push-Button

 Use a < 1 mm pushrod or similar part to access the push-bu

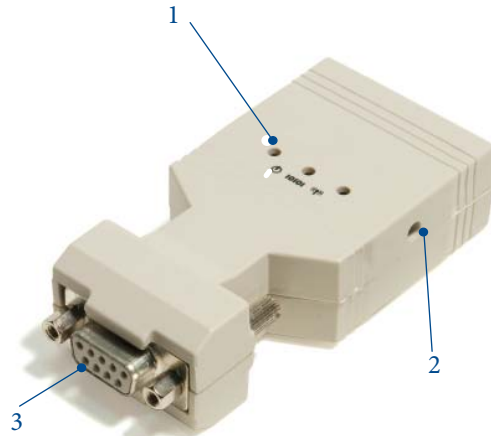

Fig. 2-8: Mesh Gate front view



Fig. 2-9: Mesh Gate back view

Table 2-2: LEDs assignment

LED	Position	LED status	Description
Power	Left	Green ON	Power OK
		OFF	Power has been removed
Communication	Middle	Green ON	ModBus mode
		Amber ON	Standard (MASC) mode for Meshscape Network Monitor or Meshscape programmer use
		Red ON	Programming in progress
RF activity	Right	Green ON	Initialization, MG not operating
		Flashing Green	RF activity

2.4 Mesh Node description

This product is now available in 2 versions:

- Long Range (**L**) with RF power max. 10 mW
- Extra Long Range (**XL**) with RF power max. 100 mW

1. LED indicators (see table hereunder)
2. Power supply 9 V DC
3. Connector panel access cover (ON/OFF switch)

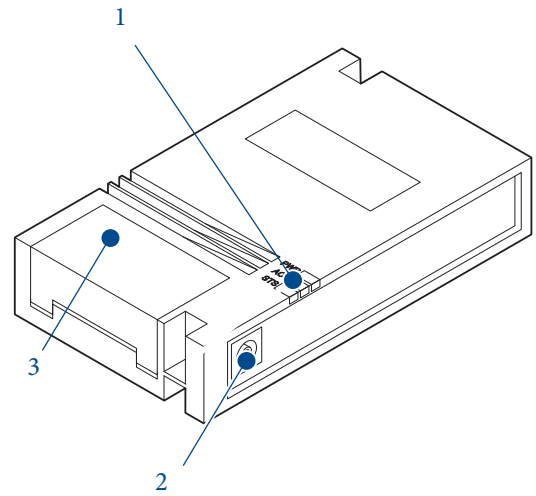

Fig. 2-10: Mesh Node

Table 2-3

LED	LED Status	Description
PWR	ON	Power ON
	OFF	No Power
RF Activity	Flashing	Mesh Node detects RF activity. The RF activity LED will flash when detecting valid packets (packets destined for device) and may also flash when detecting invalid packets (packets destined for other devices) or environmental noise. Only valid packets are processed by the device.
	OFF	No RF activity detected.
STS	ON Solid Green	Device has established two or more connections with other devices.
	Blinking	The Mesh Node has established a single connection; additional routers may be needed to increase robustness.
	OFF	The Mesh Node is not on the MeshScape network : additional routers are absolutely needed in order this device be connected to the network.

2.5 Network

2.5.1 Network Characteristics

- Radio standard: 802.15.4
- Protocol:Proprietary
- RF Band:2.4 GHz
- RF Power and Operating range (line of sight):

Table 2-4

	MG-L and MN-L	MG-XL and MN-XL	EMN
RF max. Power	10 mW (10 dBm)	100 mW (20 dBm)*	10mW (10dBm)
Operating range between EMN and MG or MN	30 m (95 ft)	30 m (95 ft)	-
Operating range between MG or MN	149 m (460 ft)	260 m (850 ft)	-

* 100 mW: when allowed, according to country regulations



WARNING

DISTANCE MAY CHANGE WITH REGARDS TO BUILDING CONFIGURATION AND NETWORK LAYOUT.

2.5.2 Introduction

The radio network is self-configuring. The nodes IDs are factory programmed and usually do not need to be changed.

In a mesh network, there are often several different routes possible for a message from a EMN to the MG through Mesh Nodes. The path with the least **hops** (RF steps between 2 nodes) to routers will be used if available.

More routers can be used for long distances or to add routes from a EMN to the MG in areas with a changing environment.

Different topologies are available (See figures).

2.5.3 Description

Each EMN and the MG are equipped with a radio module.

The measurement values of the EMN are buffered in the gateways RAM.

The MG is updated by each EMN periodically depending on the network configuration.

When addressing a EMN Modbus slave, the MG responds directly. As the MG contains an image of the EMN values, there is no need to pass the message on to the EMN.

A write command, however, is forwarded to the EMN, a delay of 2 to 4 minutes can occur for the response message.



Refer to «Modbus interface» on Chapter 4.4.1. for more information.

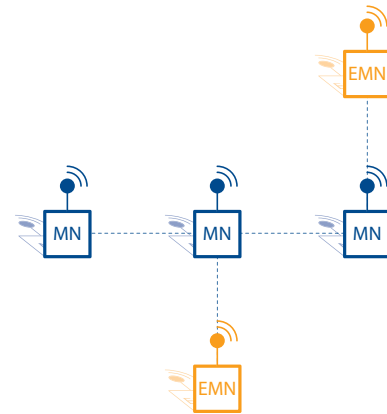

Fig. 2-11: Single path between MG, MN and EMN (Linear)

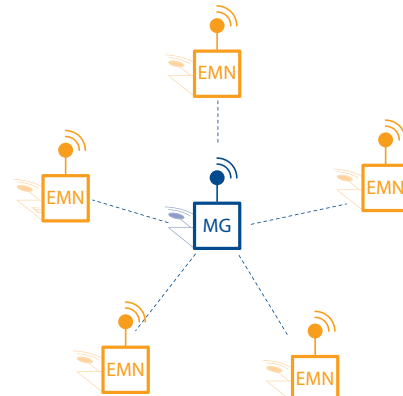

Fig. 2-12: Combination of low power EMN with a MG (Simple Star)

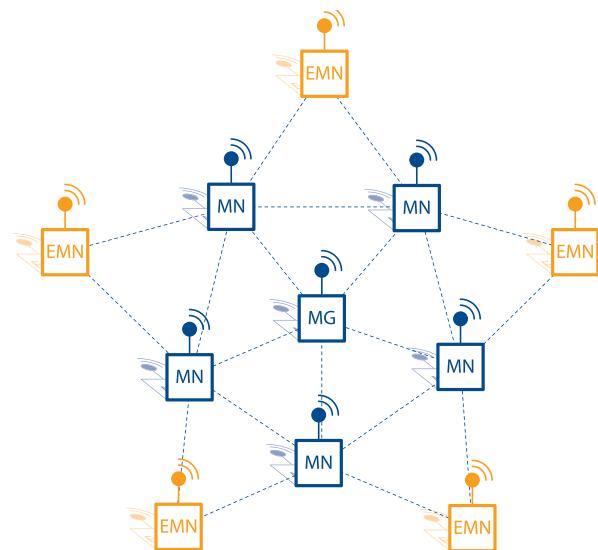

Fig. 2-13: Network with a combination of reliability and low power (Star Mesh Network Topology)

3. HARDWARE INSTALLATION AND CONTROL

This chapter describes how to install the hardware to set up the Wireless Mesh Sub-meter Network.

3.1 Important warning and notices

⚠ DANGER RISK OF ELECTRICAL SHOCK: THIS EQUIPMENT CONTAINS HAZARDOUS VOLTAGE THAT MAY CAUSE SERIOUS INJURY OR DEATH TO PERSONS IF PRECAUTIONS WITHIN THIS GUIDE ARE NOT FOLLOWED. DO NOT REMOVE ANY PART OR CUT SENSOR CABLE OF THE EMN.

⚠ CAUTION THIS ELECTRIC EQUIPMENT MUST BE USED IN ELECTRIC / ELECTRONIC EQUIPMENT WITH RESPECT TO APPLICABLE STANDARDS AND SAFETY REQUIREMENTS IN ACCORDANCE TO THE MANUFACTURER'S OPERATING INSTRUCTIONS.

⚠ WARNING INSTALLATION AND SERVICE MUST BE DONE BY QUALIFIED PERSONNEL ONLY ON POWER LOCKED CABINET.

⚠ WARNING IN CASE THIS EQUIPMENT WOULD BE USED IN A DIFFERENT MANNER AS SPECIFIED WITHIN THIS GUIDE, THE PROTECTION PROVIDED BY THE EQUIPMENT MAY BE IMPAIRED.

⚠ CAUTION EMN AND ITS PREWIRED CURRENT TRANSFORMER ARE DESIGNED FOR USE IN RESTRICTED ACCESS CABINET.

- Do not install the equipment in cabinet which does not provide a sufficient protection level according to the datasheet
- Do not remove or change any part of the product, it may damage it or other equipment or cause serious injury or death.
- In case of accidental degradation of enclosure or other part, do not install the equipment or remove it from installation and carry out its replacement.
- Do not degrade or cut any part of the enclosure and cables.

3.2 Before You Start

- Check carefully that the EMN Model received is appropriate for the system to be monitored. Otherwise, wrong or incomplete data may be sent to the Mesh Gate (MG).
- Read carefully this manual and take care of the warning notes.

3.3 Network deployment recommendations

Prior to define your network and the elements location, read the following informations.

⚠ WARNING IF POSSIBLE, FOR AN EASIER DEPLOYMENT OF A NEW NETWORK, THE MESH GATE SHOULD BE POWERED BEFORE ALL OTHER NODES .

⚠ WARNING ALL DEVICES ARE DESIGNED FOR INDOOR USE ONLY.

3.3.1 Basic guidelines

3.3.1.1 Building audit

Mesh devices all communicate via wireless radio frequencies and are influenced by several factors (electrical wires, metal objects, heavy concrete walls, direction of installed devices, etc.).

Consider the following items in network configuration:

- Number of floors, layout;
- Network topology – dense versus spread out/serial;
- Type of building material;
- Power availability for nodes not attached to meters;
- Any known obstacles or RF interferences (Heating pipes, electrical room, etc.);
- “Bridge” Mesh Node Placement;
- Detect other 2.4 GHz interference.

3.3.1.2 Walls and floors

Inside a building, radio waves deflections on walls and other objects create interferences.

In case of wall mounting or crossing, take care about both sides of the construction. Depending on materials and wall or floor thickness, radio signal strength will get reduced and distance between devices will be affected.

Usually, floors are hardest to penetrate due to materials used (concrete, cement, tiles, etc.). So, always consider placing routers in stairways and other open spaces available between the floors.

3.3.1.3 Different materials

Glass, sheet rock and wood have least impact to the radio signal.

Concrete and brick walls are much harder to penetrate (maximum distance is half), but anyway distance between two devices will depend on how thick and how many obstacles there are in a way.

Metal is virtually impossible to penetrate and radio communication through such material is only possible thanks to actual open spaces (slits, holes and cracks in the metal.)

3.3.2 Network topologies

- Network strength primarily depends on the network topology .
- The more links the devices will have with other nodes, the more robust and reliable the network will be.

3.3.2.1 Best Case Scenario (Star-Mesh topology)

Ideal Meshscape topology is “Star-Mesh”, where all nodes are evenly distributed from the Gateway and have multiple communication links.

In such configuration, all devices can communicate with multiple nodes, so that if one mesh node fails or if a radio link experiences interference, the network will reconfigure itself through the remaining nodes. Having multiple routes to the gateway will also decrease the estimated sampling rate.

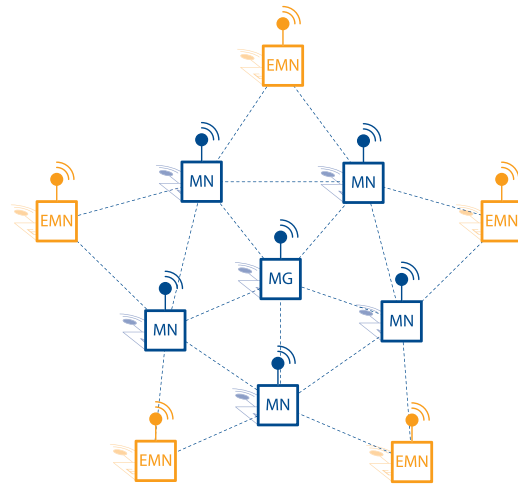

Fig. 3-1: Network with a combination of reliability and low power (Star Mesh Network Topology)

3.3.2.2 Worst Case Scenario (Data Bottle Neck)

In some cases sensors might be located far away from the Gateway and all data from the network has to travel to its final location over single path. Such situation creates bottlenecks and increases the risk of losing data packets.

Always try to avoid such topologies by adding additional routers to provide more links to the gateway.

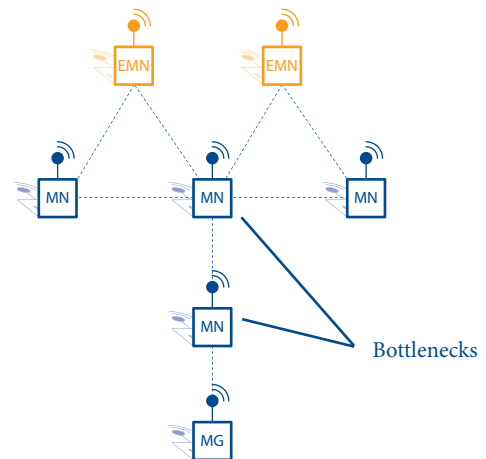

Fig. 3-2: Single path between MG and MN (linear)

3.3.3 EMN location

3.3.3.1 Basic guidelines

To obtain the best effectiveness of the network, apply the following recommendations.

- Do not install EMN in front of or close to metallic parts. That may reduce the efficiency of the embedded antenna.
- Avoid proximity of Electromagnetic Induction.
- Respect the illustrated layout to insure an optimized orientation of the antenna.

3.3.3.2 Inside a metallic cabinet

When EMN has to be placed inside a metallic cabinet, its location is even more important.

The cabinets are never completely sealed thanks to small open spaces and allow certain radio communication, but significantly reduce signal strength. To get the best effectiveness, apply the following recommendations:

- Do not install EMN in the centre of the cabinet where most electrical cables are located.
- Put EMN on one side, in front of any door slit or any window (if existing).
- If there is some hole on bottom or top of the cabinet for cables pathways, put EMN in front of it.
- Add systematically a Mesh Node in the vicinity of the cabinet (1m) to ensure robust communications.

3.3.4 Mesh Gate location and connection

- It is always preferable to place the Mesh Gate in middle of network.
- Need for PC (start-up/diagnostic/troubleshooting)

- A** Power on the MG 6424 by plugging the DC power supply adaptor (refer to LEM's accessory list)
- B** Connect the Data Port RS xxx to the COM port of the Computer or application device.

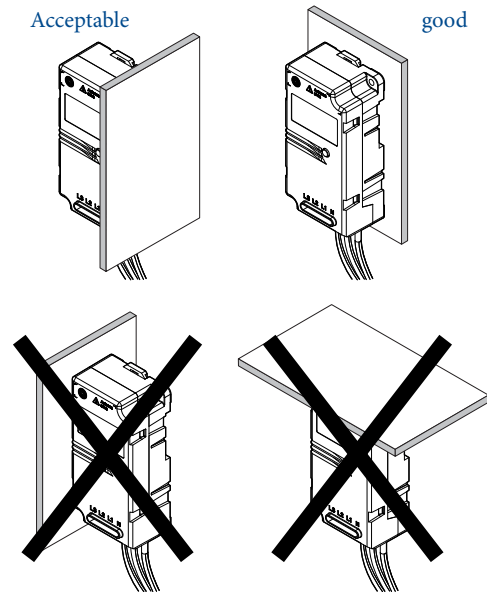

Fig. 3-3: Avoid the proximity of the antenna with metal parts

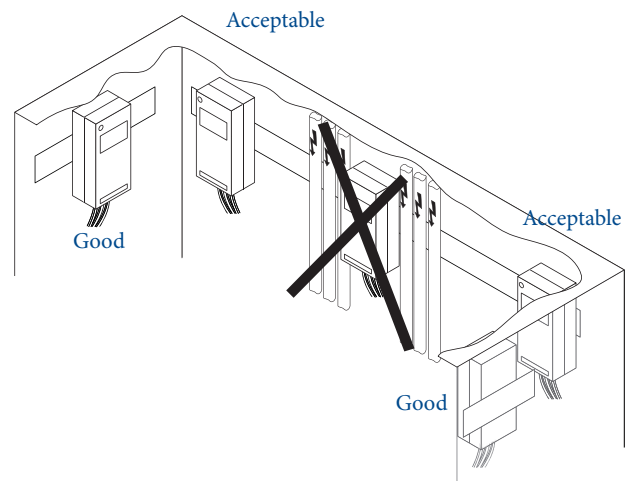

Fig. 3-4: EMN Location inside a metallic cabinet

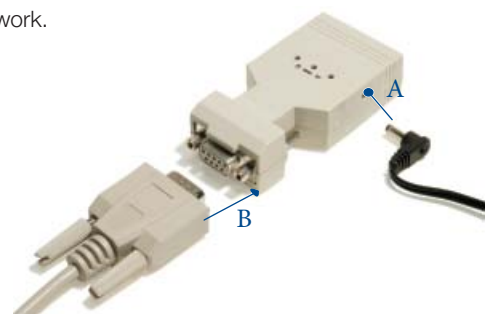

Fig. 3-5: Connect the Mesh Gate data port to the PC

3.3.5 Mesh Node location and connection

Orientation of the nodes in relation to other devices on the network impacts radio signal strength.

- Avoid placing Mesh Node right under an EMN.

⚠ WARNING TAKE CARE IF FIXING MESH NODE HORIZONTALLY ON A METALLIC PLANE TO LET A MINIMUM FREE INTERVAL (3-5 MMS) BETWEEN BOTH AREAS IN REGARDS.

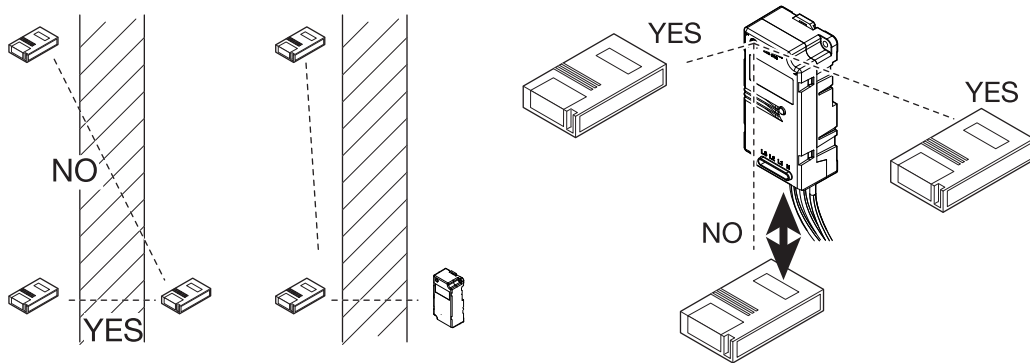

Fig. 3-6: location advising

Best radio signal is observed when all Mesh Node devices are positioned horizontally:

Good radio signal is also observed when one device is positioned horizontally and other vertically:

Radio signal is weaker, when all devices are positioned vertically:

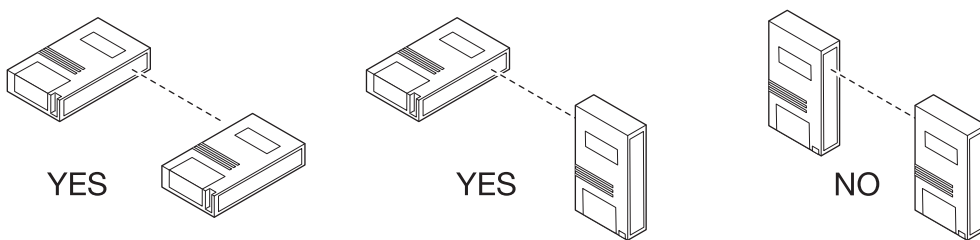

Fig. 3-7: Devices position

- A Power on the Mesh Node by plugging the power supply adaptor 9V (1).

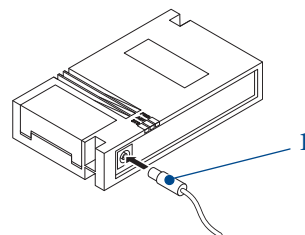

Fig. 3-8: Connect the Mesh Node power supply

3.4 Energy Meter Node Mounting

⚡ DANGER MAKE SURE THAT THE LOCATION WHERE THE ENERGY METER NODE HAS TO BE FIXED IS POWERED OFF.

⚠ WARNING EMN MODULE MUST BE INSTALLED VERTICALLY AS SHOWN ON THE FIGURE BELOW.

3.4.1 Wall and panel Mounting

- A Prepare the mounting holes.
- B Fixe the EMN to the wall or the panel with the screws (1).

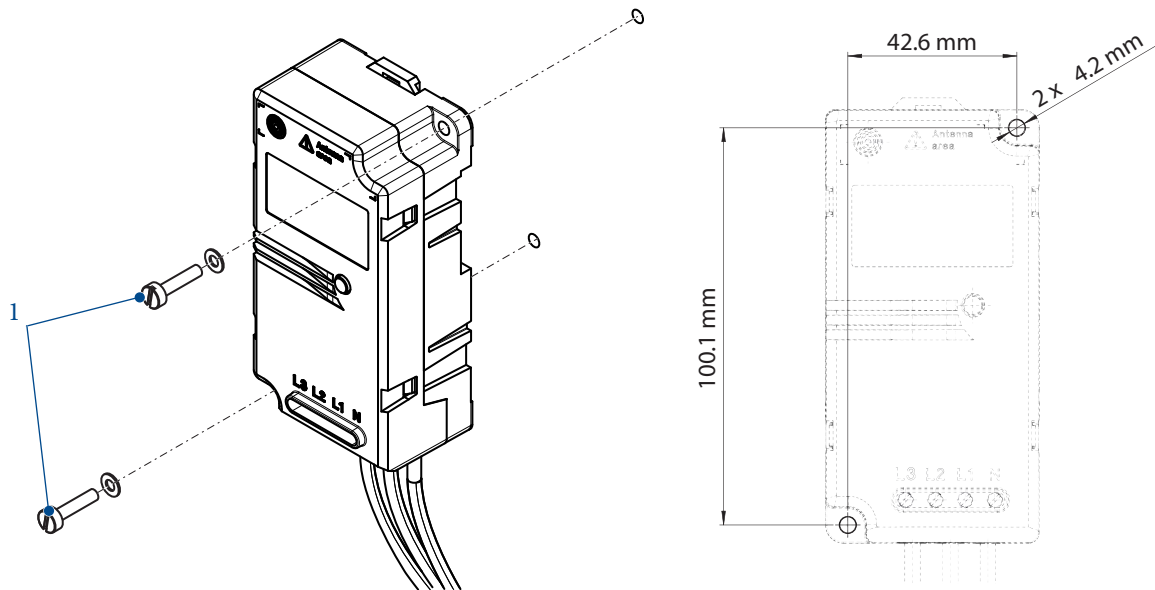

Fig. 3-9: Fixing the EMN on a wall or panel

Note: Use max fastening torque 2.8 Nm (2 Lb.-Ft)

3.4.2 DIN Rail Mounting

- A Clip the EMN on the DIN Rail (3).
- B Pull up the clipping fixture (2) to remove the EMN from the DIN Rail.

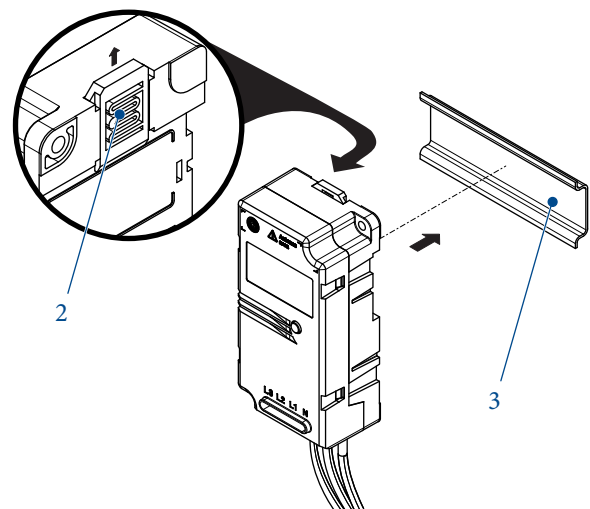

Fig. 3-10: Fixing the EMN on the DIN Rail

3.4.3 Current sensors mounting

⚠ DANGER MAKE SURE THAT THE POWER CABLE ON WHICH THE CURRENT SENSOR IS ATTACHED IS POWERED OFF.

⚠ CAUTION THESE CURRENT SENSOR ARE DESIGNED FOR LESS THAN 50 OPEN/CLOSE CYCLES, DO NOT USE AS A CLAMP ON METER.

⚠ CAUTION THESE CURRENT SENSOR HAVE BEEN DESIGNED FOR ISOLATED CABLE USE ONLY.

3.4.3.1 Current Transformer

⚠ WARNING KEEP THE MATING SURFACES (2) PARTICLE FREE OTHERWISE ACCURACY MAY BE DEGRADED.

A Respect the Current Transformer phase allocation according to Voltage phase allocation.

 If the phase allocation is wrong, the EMN will send incorrect energy data.

 Refer to chapter 2.2.2 for more details about the phase allocation.

B Make sure that the arrow (3) shows the way of the positive current flow from the generator to the load. In this case, the label (6) is facing the load.

 This allows the EMN to calculate Active Energy with the right sign.

C Close the Current Transformer around the cable (1).

D Use the mounting clip (5) to attach the Current Transformer on the cable (4).

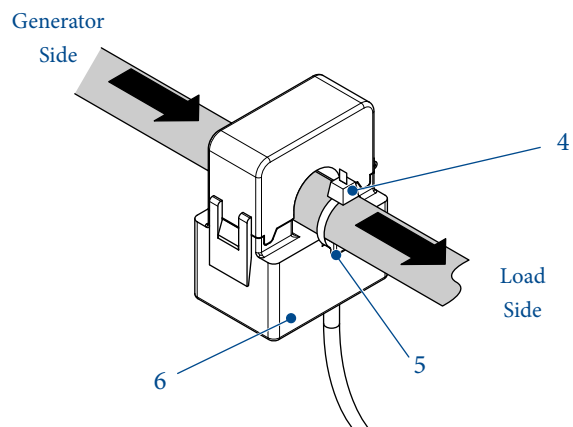
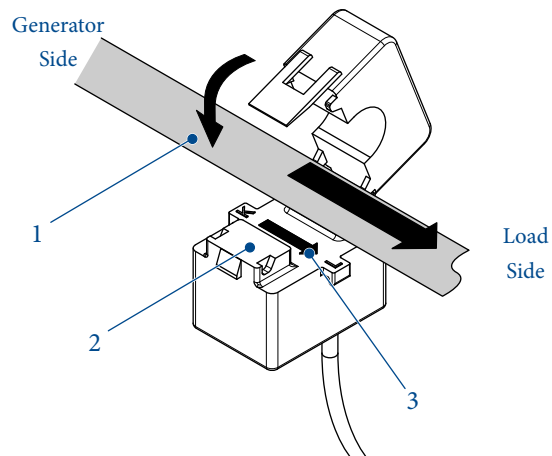



Fig. 3-11: Current Transformer mounting

3.4.3.2 Rogowski coil

⚠ WARNING IN ORDER NOT TO DRAMATICALLY DEGRADE THE ACCURACY , DO NOT STRESS THE COIL APPLYING ANY KIND OF MECHANICAL CONSTRAINT (TWISTING, PRESSING, PUNCHING, STRONG BENDING, ...)

A Respect the Rogowski coil phase allocation according to Voltage phase allocation.

 If the phase allocation is wrong, the EMN will send incorrect energy data.

 Refer to chapter 2.2.2 for more details about the phase allocation.

B Make sure that the arrow (3) shows the way of the positive current flow from the generator to the load.

 This allows the EMN to calculate Active Energy with the right sign.

C Close the Rogowski (2) coil around the cable (1)

⚠ WARNING ARROW INDICATING THE CURRENT DIRECTION MUST BE INSIDE THE LOOP (3) WHEN CLOSED AS SHOWN BESIDE

 Be sure that the coil is well locked (fully inserted until the click is heard (4) otherwise accuracy may be degraded.

D The Rogowski coil can be let free around the cable / conductor and doesn't need to be attached.

The accuracy won't be affected more than 0.5%, as described within the datasheet, whatever the position of the coil around the conductor.

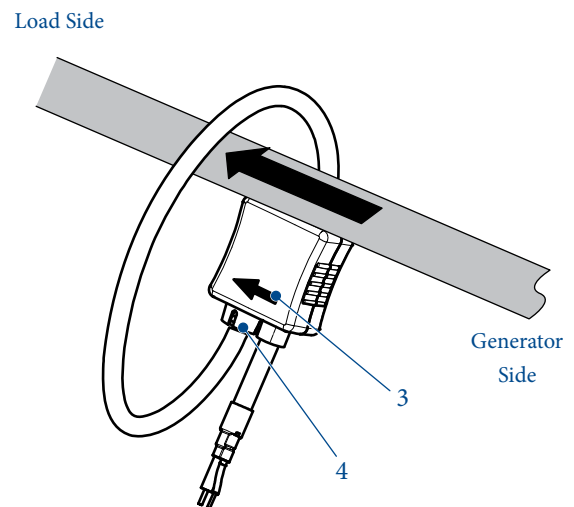
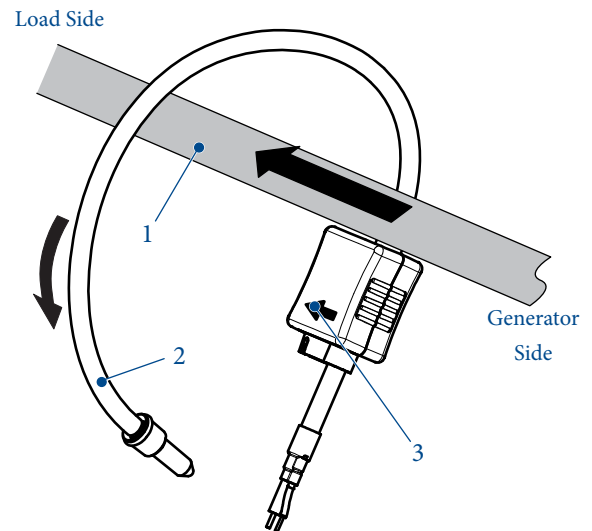

Fig. 3-12: Rogowski coil mounting

3.4.4 Voltage Input connection

⚠ WARNING

FUSE OR CIRCUIT BREAKER MUST BE INSTALLED BETWEEN THE MAIN SUPPLY AND THE EMN FOR LINE PROTECTION. THE PROTECTION DEVICE MUST BE INSTALLED NEAR THE EMN, MUST BE EASILY ACCESSIBLE AND MUST BE IDENTIFIED AS PROTECTION UNIT OF THE EMN MODULE.

Use a protection with the following characteristics:

Table 3-1:

Protection range [A]	Wiring [mm ²]	Single fault condition Max trip time [ms]
6.3	1	30ms
10	1.5	30ms
16	2.5	30ms

⚠ DANGER

MAKE SURE THAT THE WIRES YOU CONNECT TO THE VOLTAGE INPUT ARE POWERED OFF.



Refer to «Model Description» on Chapter 2 for more details about the Wiring Diagram of the Energy Meter Node.

3.4.4.1 Line powered EMN

A Connect the wires from the line to the right Input Voltage connecting points **(1)**.

B Use 2.5 mm² wire for single wire and 1 mm² wire for 2 wires.

C Use wire > 65°C temperature grade.

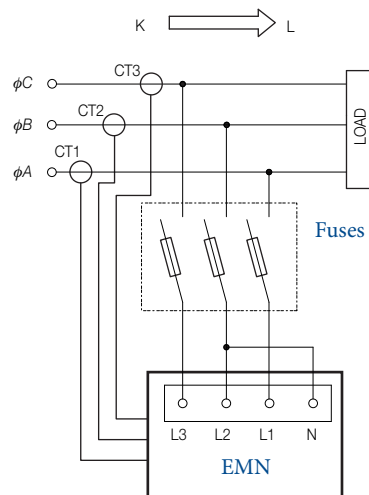

Fig. 3-13: Example of Fuse Holder connection

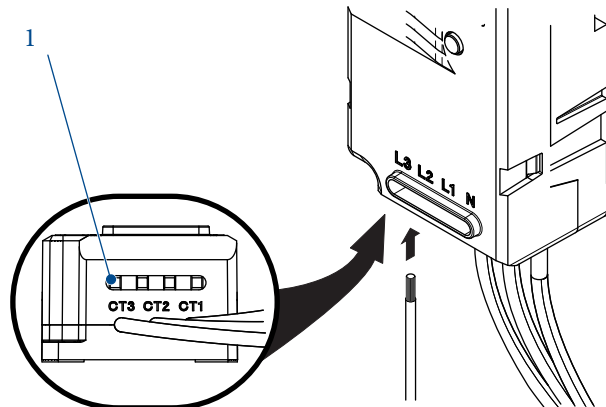

Fig. 3-14: Connecting the wires to the Input Voltage

3.4.4.2 24 V DC powered EMN (SP2 models)

⚠ WARNING EMN MAY PRESENT DYSFUNCTIONS IF THE $\pm 10\%$ TOLERANCE AROUND 24 V DC IS NOT RESPECTED.

⚠ WARNING IT IS NOT RECOMMENDED TO USE THE SAME 24 V DC POWER SUPPLY UNIT FROM OTHER DEVICES EXCEPTION OF OTHER EMN MODULES.

A Connect the 2 wires **(1)** to a 24 V DC power supply:
 Brown: +24 V DC
 Black: 0 V DC

B Connect the wire **(2)** to the earth/ground

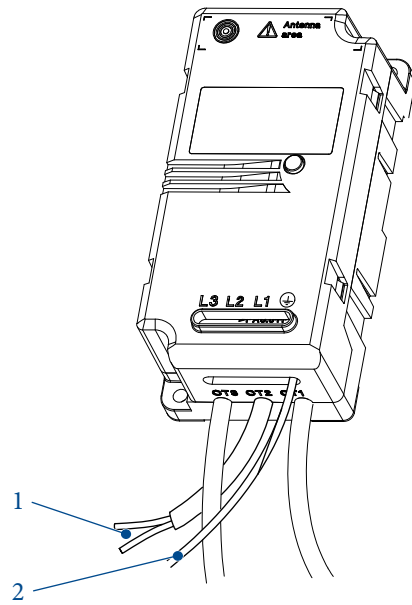

Fig. 3-15: Connecting the wires to the Input Voltage

0 V DC of the 24 V DC power supply unit is internally connected to earth/ground.

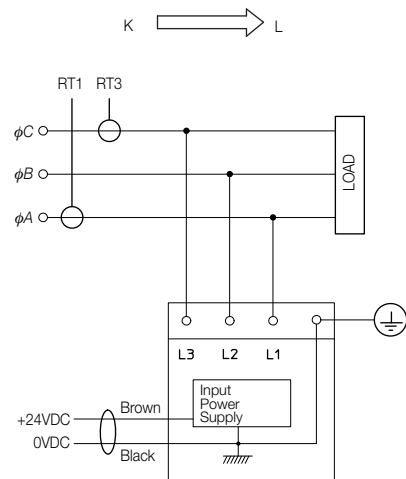

Fig. 3-16: Example of 24 V DC connection

3.4.5. LED indicator description

The LED Indicator (3) has the following status on both models:

1 blink, wait 2 seconds:

Normal operation and direct serial communication mode from firmware V2.02:

2 blinks, wait 1 second:

Radio module communication error: EMN is unable to send data.

3 blinks, wait 1 second:

Meter not synchronized to 50/60Hz: Frequency out of range of 50 Hz - 10 % to 60 Hz + 10%.

4 blinks, wait 1 second:

Comm- & Synch error together:

5 blinks, wait 1 second:

Checksum Error: If a reset-meter command followed by an OFF/ON sequence does not reset this error, the calibration memory is corrupt and the device needs to be sent back to LEM.

6 blinks, wait 1 second:

Direct serial communication mode (factory use only) until firmware V2.01.

7 blinks, wait 1 second:

Internal hardware failure.

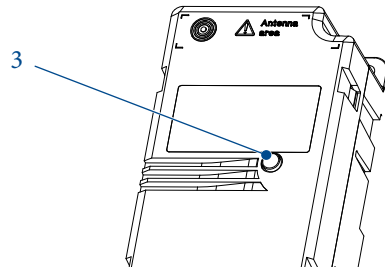

Fig. 3-17: LED indicator

3.5 Network commissioning

3.5.1 Modules Identification

Each module has two identification numbers: Group ID and Device ID, each defined by two bytes.

The Group ID and Device ID are printed on labels on:

- EMN front cover
- Mesh Node or Mesh Gate back side



All modules, including the Mesh Gate, must be set with same Group ID to communicate together on the same network. All parts are delivered from factory with default GID : 111.111

The nodes are already addressed at factory, respecting the following table:

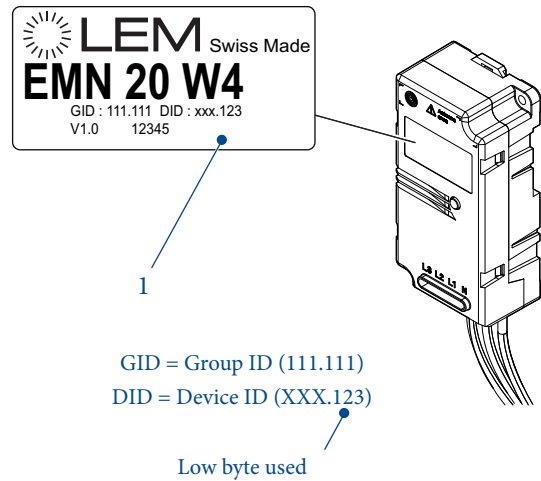

Fig. 3-18: ID labels

Table 3-2:

Device Type	Device	High byte	Low Byte (Modbus address)
End Node Devices (high byte 1 - 159)	EMN	1 - 30	1 - 216
	Wi-Pulse	31 - 40	100 - 216
	Reserved	41 - 50	100 - 216
	Wi-Temp	51 - 60	100 - 216
	Wi-Zone	61 - 70	100 - 216
Mesh Node Devices (high byte 160 - 255, except 248 & 249)	reserved	160 - 209	1 - 216
	Mesh Node	210 - 219 240 - 247	217 - 246
Mesh Gate	Mesh Gate	160 - 255 (except 248 & 249)	247

⚠ WARNING

THE DEVICE ID LOW BYTE IS ALSO THE MODBUS ADDRESS FOR THE MODULE. SO, THIS PARAMETER MUST ABSOLUTELY BE UNIQUE IN THE NETWORK BE ABSOLUTELY SURE TO HAVE ALL MODULES WITH A DIFFERENT ADDRESS BEFORE INSTALLING !

Considering the Mesh Gate, the Device ID high byte encodes the maximum number of nodes allowed in the network:

Table 3-3:

Mesh Gate ID high byte	Maximum number of nodes
170	10
200	100
220	200

⚠ WARNING

BE SURE THE MESH GATE IS APPROPRIATE TO THE NETWORK (MAXIMUM NODES).

3.5.2 Mesh Gate connection

3.5.2.1 Mode selection

By default, the Mesh Gate is configured for MODBUS mode.

The network installation might need the MeshScape Monitor application which requires the Mesh Gate to be switched to STANDARD mode (see procedure below).

This STANDARD mode provides more information on the network status.

 For MG 6424, use revision 5.2.6 or later of MeshScape Monitor application.

A Push the internal push-button once (> 1 s) in order to switch to Standard mode (MASC mode)

B Check the LED changes from green to amber (the process may take up to 15 s)

Use the same procedure to switch back to ModBus mode (toggle function).

3.5.2.2 RS 232 data port use and configuration

DB-9 style connector:

RS-232 Data Port connector with standard DCE connections for transmit data, receive data, RTS input, and CTS output.

The MG 6424 is factory configured with the following parameters:

- **Baud Rate** 115200
- **Data Bits** 8
- **Parity** None
- **Stop Bits** 1

Only the Modbus communication baud rate may be modified with the following procedure:

A Switch the MG 6424 to Standard (MASC) mode

B Open the application MeschScape Plus Programmer (release 3.00 or later)

C Select «OB Gateway» in the Device Select Box (1)

D Select the right programming Port (5)

E Disable the Program Flash selection (un-tick)

F Enable the Configure EEPROM (tick) and select the path (7) to the data file (.csv) corresponding to the right baud rate (included within the MeshScape application package)

Available Baud Rates: 2400, 4800, 9600, 19200, 38400, 57600, 115200

G Click on the «Program» soft key (6)

 Disable the 2 boxes «Group & Device ID» and «Radio Configuration».

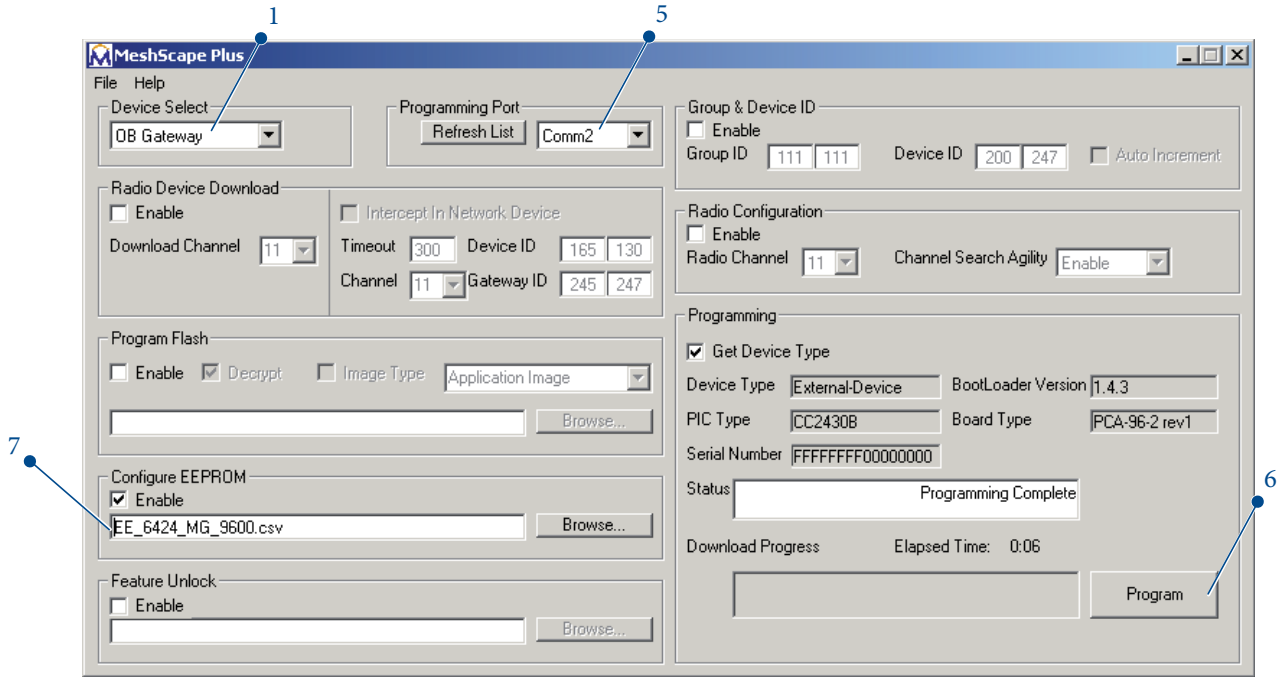

Fig. 3-19: MeshScope Programmer

3.5.2.3 RS 485 data port use and configuration

DB9 connection special wiring:

In order to activate the RS 485 mode, please connect the RS Data port as follows:

- As soon as the Mesh Gate is powered on, it will choose the serial mode RS 232 or RS 485 according to the DB9 wiring. This mode will remain until the Mesh Gate will be power cycled (removing the DB9 connector will have no effect).
- RS 485 mode is available on Mesh Gate wearing the date code 10267 or later with FW version (or later) 1.5.15 (Mesh Gate 100 and Mesh Gate 200) or 1.7.5.15 (Mesh Gate 10). Upgrade of older Mesh Gate (before date code 10267) is not possible (different hardware version)
- For configuration modification refer to 3.5.2.1 paragraph; it must be done on RS 232 mode only (remove the special wiring used for RS 485 and power cycle the device).
- RS 485 mode allows the use of the Mesh Gate on a RS 485 link but with only one Mesh Gate on the bus as the Modbus address is set to 247 and can not be changed.

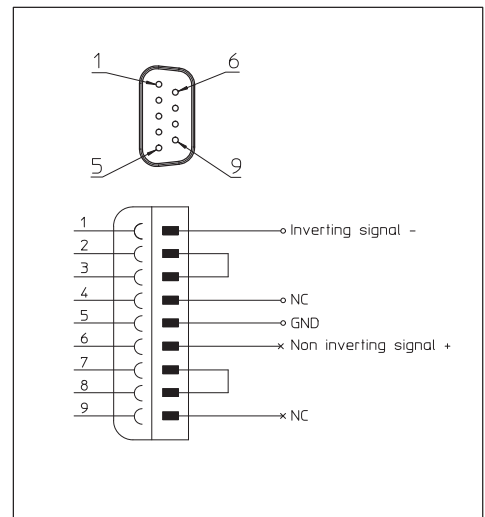

Fig. 3-20: Mesh Gate RS 485 wiring diagram

3.5.3 MeshScope Monitor

With MG 6424, use only MeshScope Monitor release 5.2.6 or later.

With the Mesh Gate switched to **Standard (MASC)**, the **MeshScope Monitor** software can be used to view the network.

1. Menu bar
2. Mesh Gate details
3. Network details
4. Mesh Node (MNEN symbol) and End Node (EN symbol) device list

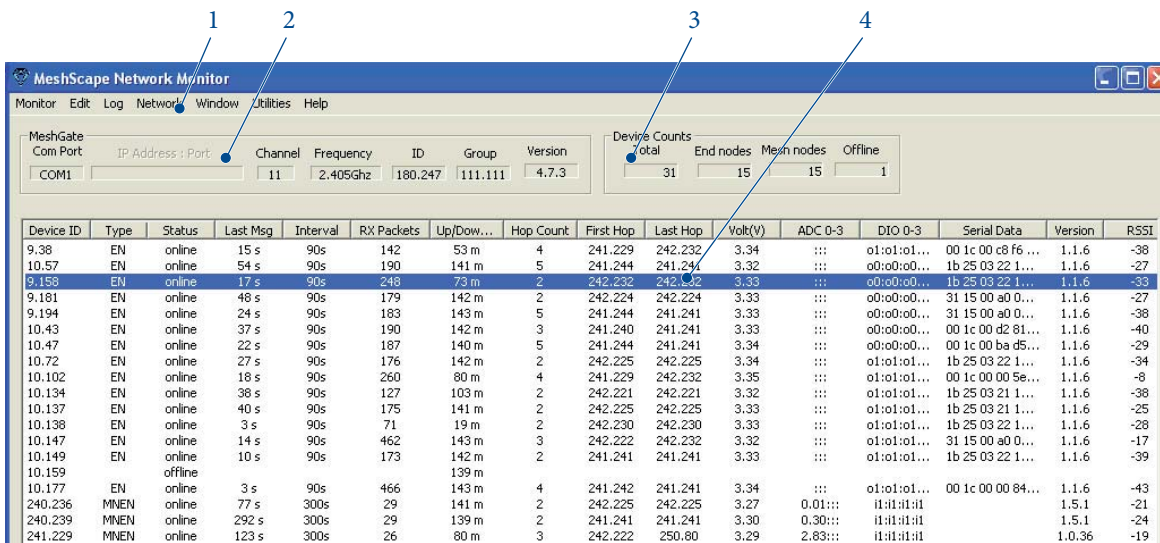

Fig. 3-24: MeshScope Monitor main screen

3.5.3.1 Network Initialisation and control

The network starts building itself once the Mesh Gate is powered on.

Depending on the physical topologies, a network may take up to 5 minutes to be formed.

- Each router (Mesh Node) or End Node (EMN, Wi-Pulse) that is powered on should be seen in the monitor application.
- Hop count, with first hop and last hop, can help to determine the physical pathway from End Node to the Mesh Gate. Such information can help to check if any Mesh Node is strategic (lot of traffic going through it) and may require to be doubled.
- RSSI (Received Signal Strength Information) can help to determine if the communication is too weak (value lower than -45) and so if additional Mesh Node is necessary
- If an End Node transducer is not “seen” by the Mesh Gate, verify the distance to the next Mesh Node / Mesh Gate and their locations. An additional Mesh Node should be placed between the EMN and the nearest Mesh Node.
- To verify the functioning of the EMN, observe the serial data of the corresponding line. At regular intervals there will be new data written.

This page is intentionally left blank

4. SOFTWARE INTERFACE

4.1 Introduction

This chapter describes the parameters and the registers available for software development.

Table 4-1 Modbus Register Map for all devices

Modbus Register	Description	Type / length	Storage	Unit	Access
201	Hop count	U16	V		R
202	First hop ID	U16	V		R
203	Last hop ID	U16	V		R
204	RSSI (MSB) & Supply voltage (LSB)	U16	V		R
220	Device ID (high byte and low byte)	U16	NV		R
221	Group ID (high byte and low byte)	U16	NV		R
222	Sampling interval	U16	NV		R
224	Network channel (11-26)	U16	NV		R
347	Device ID* (high byte and low byte)	U16	NV		W
348	Group ID* (high byte and low byte)	U16	NV		W
349	Sampling interval	U16	V		W
351	Network channel (11-26)	U16	NV		W

* Before modifying any of both registers, refer to chapter 4.2.17

4.2 Energy Meter Node

4.2.1 Modbus Register Table

Following table reports Modbus registers specific to EMN products.

Table 4-2 EMN Modbus Register Map

Modbus Register	Description	Type / length	Storage	Unit	Access
0	Active Energy Consumption, Phase 1 MSW	S32	NV	Wh	R
1	Active Energy Consumption, Phase 1 LSW		NV	Wh	R
2	Active Energy Consumption, Phase 2 MSW	S32	NV	Wh	R
3	Active Energy Consumption, Phase 2 LSW		NV	Wh	R
4	Active Energy Consumption, Phase 3 MSW	S32	NV	Wh	R
5	Active Energy Consumption, Phase 3 LSW		NV	Wh	R
6	Active Energy Consumption, Phase Sum MSW	S32	NV	Wh	R
7	Active Energy Consumption, Phase Sum LSW		NV	Wh	R
8	Reactive Energy Consumption, Phase 1 MSW	S32	NV	VARh	R
9	Reactive Energy Consumption, Phase 1 LSW		NV	VARh	R
10	Reactive Energy Consumption, Phase 2 MSW	S32	NV	VARh	R
11	Reactive Energy Consumption, Phase 2 LSW		NV	VARh	R
12	Reactive Energy Consumption, Phase 3 MSW	S32	NV	VARh	R
13	Reactive Energy Consumption, Phase 3 LSW		NV	VARh	R
14	Reactive Energy Consumption, Phase Sum MSW	S32	NV	VARh	R
15	Reactive Energy Consumption, Phase Sum LSW		NV	VARh	R

Modbus Register	Description	Type / length	Storage	Unit	Access
16	Apparent Energy Consumption, Phase 1 MSW	U32	NV	VAh	R
17	Apparent Energy Consumption, Phase 1 LSW		NV	VAh	R
18	Apparent Energy Consumption, Phase 2 MSW	U32	NV	VAh	R
19	Apparent Energy Consumption, Phase 2 LSW		NV	VAh	R
20	Apparent Energy Consumption, Phase 3 MSW	U32	NV	VAh	R
21	Apparent Energy Consumption, Phase 3 LSW		NV	VAh	R
22	Apparent Energy Consumption, Phase Sum MSW	U32	NV	VAh	R
23	Apparent Energy Consumption, Phase Sum LSW		NV	VAh	R
24	Energy Counter Timestamp, Min / Sec	U16	V		R
25	Energy Counter Timestamp, Day / Hour	U16	V		R
26	Energy Counter Timestamp, Year / Month	U16	V		R
27	Line Frequency	U16	V	Hz	R
28	Recording Interval Timestamp, Min / Sec	U16	V		R
29	Recording Interval Timestamp, Day / Hour	U16	V		R
30	Recording Interval Timestamp, Year / Month	U16	V		R
31	Recording Interval Active Energy, Phase 1	S16	V	Wh	R
32	Recording Interval Active Energy, Phase 2	S16	V	Wh	R
33	Recording Interval Active Energy, Phase 3	S16	V	Wh	R
34	Recording Interval Active Energy, Phase Sum	S16	V	Wh	R
35	Recording Interval Reactive Energy, Phase 1	S16	V	VARh	R
36	Recording Interval Reactive Energy, Phase 2	S16	V	VARh	R
37	Recording Interval Reactive Energy, Phase 3	S16	V	VARh	R
38	Recording Interval Reactive Energy, Phase Sum	S16	V	VARh	R
39	Recording Interval Apparent Energy, Phase 1	U16	V	VAh	R
40	Recording Interval Apparent Energy, Phase 2	U16	V	VAh	R
41	Recording Interval Apparent Energy, Phase 3	U16	V	VAh	R
42	Recording Interval Apparent Energy, Phase Sum	U16	V	VAh	R
43	Maximum Current in Interval, Phase 1	U16	V	A	R
44	Maximum Current in Interval, Phase 2	U16	V	A	R
45	Maximum Current in Interval, Phase 3	U16	V	A	R
46	Minimum Voltage in Interval, Phase 1	U16	V	V	R
47	Minimum Voltage in Interval, Phase 2	U16	V	V	R
48	Minimum Voltage in Interval, Phase 3	U16	V	V	R
49	EMN models Configuration (current range, connection diagram)	U16	NV		R
50	Software Version (bits 8-15) Software Revision (bits 0-7)	U16	NV		R
51	Status Word	U16	NV		R
52	Command Word	U16	V		R/W
53	Recording Interval Time Setting	U16	NV	min	R/W
70	Zero Power Detection	U16	NV	LSB	R/W

Some networks parameters, general to any node, are also accessible through Modbus registers and are available for all Mesh devices.



Notes on table: NV: Non-Volatile, restored after power-cycle; V: Volatile. S: Signed; U: Unsigned;

R: Read; W: Write;

4.2.2 Scaling factors

4.2.2.1 For EMN Line powered up to 300 V_{rms}

Scaling Factor Table								
	Divide the result by:							
Current range	5A	20A	50A	100A	200A	500A	1000A	2000A
Active Energy Wh [Intvl]	64	16	6.4	3.2	1.6	0.64	0.32	0.16
Active Energy Wh [Counter]	8	2	0.8	0.4	0.2	0.08	0.04	0.02
Reactive Energy VARh [Intvl]	64	16	6.4	3.2	1.6	0.64	0.32	0.16
Reactive Energy VARh [Counter]	8	2	0.8	0.4	0.2	0.08	0.04	0.02
Apparent Energy VAh[Intvl]	64	16	6.4	3.2	1.6	0.64	0.32	0.16
Apparent Energy VAh[Counter]	8	2	0.8	0.4	0.2	0.08	0.04	0.02
V _{rms}	25	25	25	25	25	25	25	25
I _{rms}	1200	300	120	60	30	12	6	3
Frequency	16	16	16	16	16	16	16	16

 **Note on table:** 5 A and 50 A models no longer used

4.2.2.2 For EMN/SP2 24 V_{DC} powered

Scaling Factor Table					
	Divide the result by:				
Current range	100A	200A	500A	1000A	2000A
Active Energy Wh [Intvl]	1.6	0.8	0.32	0.16	0.08
Active Energy Wh [Counter]	0.2	0.1	0.04	0.02	0.01
Reactive Energy VARh [Intvl]	1.6	0.8	0.32	0.16	0.08
Reactive Energy VARh [Counter]	0.2	0.1	0.04	0.02	0.01
Apparent Energy VAh[Intvl]	1.6	0.8	0.32	0.16	0.08
Apparent Energy VAh[Counter]	0.2	0.1	0.04	0.02	0.01
V _{rms}	12	12	12	12	12
I _{rms}	60	30	12	6	3
Frequency	16	16	16	16	16

 **Note on table:** Intvl : Interval

4.2.3 Energy counters (register 0 to 26)

These objects contain the total consumed energy measured by the EMN. Writing the reset command to the command word resets the energy counters, the recording interval counters as well as the on-going interval accumulated values.

The time-stamp of the energy counters is written into the register when the data is sent to the gateway.

The energy counters will count positive for energy consumed, negative for energy generated and pushed into the grid.

Active, reactive and apparent energy consumption values are stored as 32-bit values, thus using 2 Modbus registers. The lower register address contains the high word (MSW), the higher register contains the low word value (LSW).

- Registers 0 to 26



Notes:

MSW: Most Significant Word.

LSW: Least Significant Word

0	1
16-bits	16-bits
MSW	LSW

4.2.4 Recording Interval based energy (register 28 to 48)

Energy is integrated over a recording time interval, which is configurable.

The nominal energy is calculated over the selected period with nominal current and nominal input voltage. The last completed interval values are stored in the register map.

The timestamp is set in the **Timestamp** Register at the end of the integration interval.

- Registers 28 to 48

4.2.5 Recording Interval Time (register 53)

The recording interval time is a **configurable parameter** that defines the recording interval in **minutes**.

It can take the values 5, 6, 10, 12, 15, 20, 30.

The start of such an interval is at the hour + n* interval.

When writing a value other than the ones listed to this parameter it will be discarded and the EMN will continue to use the previous set value.

Note that the **Mesh Gate** will respond with an **“ACK”** to a write of a non-valid value as it **does not check** the contents of the message sent to the **EMN**.



When changing the interval time, the EMN will calculate the end of the next recording interval time while keeping the current interval measurements. This means that at the end of the Recording interval, the timestamp will be correct with respect to the new setting, but the first interval values are not guaranteed to be integrated over the set interval time and thus should be discarded by the master application software.



Important notice:

Because of the limited capacity of the recording interval based energy registers, the internal time value must be adapted to the current load in order to keep the absolute raw value, before scaling factor, below 2^{15} (32767) for active and reactive energy or 2^{16} (65535) for apparent energy.

Refer to the tables below that give calculated register values at different loads for a nominal voltage of 240 V (or 480 V for a SP2 model) and $\cos \varphi = 0$.

Bold values in colour are above the limit and will be uncorrectly reported

Load current Interval Time (min)	25% I _{pn}	50% I _{pn}	100% I _{pn}	120% I _{pn}
5	1600 / 4800	3200 / 9600	6400 / 19200	7680 / 23040
6	1920 / 5760	3840 / 11520	7680 / 23040	9216 / 27648
10	3200 / 9600	6400 / 19200	12800 / 38400	15360 / 46080
12	3840 / 11520	7680 / 23040	15360 / 46080	18432 / 55296
15	4800 / 14400	9600 / 28800	19200 / 57600	23040 / 69120
20	6400 / 19200	12800 / 38400	25600 / 76800	30720 / 92160
30	9600 / 28800	19200 / 57600	38400 / 115200	46080 / 138240

Active or reactive Energy registers values (One phase / phases Sum) at different loads with nominal voltage 240 V or 480 V for SP2 model and $\cos \varphi = 0$.

Load current Interval Time (min)	25% I _{pn}	50% I _{pn}	100% I _{pn}	120% I _{pn}
5	1600 / 4800	3200 / 9600	6400 / 19200	7680 / 23040
6	1920 / 5760	3840 / 11520	7680 / 23040	9216 / 27648
10	3200 / 9600	6400 / 19200	12800 / 38400	15360 / 46080
12	3840 / 11520	7680 / 23040	15360 / 46080	18432 / 55296
15	4800 / 14400	9600 / 28800	19200 / 57600	23040 / 69120
20	6400 / 19200	12800 / 38400	25600 / 76800	30720 / 92160
30	9600 / 28800	19200 / 57600	38400 / 115200	46080 / 138240

Apparent Energy registers values (One phase / phases Sum) at different loads with nominal voltage 240 V or 480 V for SP2 model and $\cos \varphi = 0$.

4.2.6 Time-stamp

The **Time-stamp** of the energy counters and the recording interval have the same format using three Modbus registers.

Each of the registers is split into two parts as shown in the following table.

Register		High byte	Low byte
24	28	Minute	Second
25	29	Day	Hour
26	30	Year	Month

4.2.7 Frequency (register 27)

The **Line Frequency** is measured on the phase of the power supply only (phase 1).

Last value of the recording interval is kept in this register.

4.2.8 Maximum Current (register 43 to 45)

The rms current is averaged over 10 line periods (200 ms in a 50 Hz system). The maximum current average of the recording interval is kept in the register.

4.2.9 Minimum Voltage (register 46 to 48)

The rms voltage is averaged over 10 line periods (200 ms in a 50 Hz system). The minimum voltage value of the recording interval is kept in the register.

4.2.10 Model Configuration (register 49)

The **Model Configuration** identifies the EMN type with its connection diagram, current caliber and voltage range.

Bit	Status Description
0,1,2	Connection
3,4,5,6	Current range
7,8,9,10	Reserved
11,12	Voltage range
13,14,15	Not used

Connection Diagram

The connection diagram is encoded in bits **(2-0)**

Description	Model	Code [bits 2-0]	Number of Current Sensors
Wye 4-wires	W4	0 0 0	3
1-Phase 2-wires	W2	0 1 0	1
2-Phase 3-wires	W3	0 1 1	2
3 single Phase on same voltage	W0	1 0 1	3
Delta 3-wires	D3	1 1 1	2

Current Range

The nominal current value of the connected current sensors can be read from bits **[6-3]**.

Current Range	Code [bits 6-3]
5 A	0000
20 A	0010
50 A	0011
100 A	0100
200 A	0101
500 A	0110
1000 A	1000
2000 A	1010

Voltage range

The type of voltage range is encoded in bits **[12-11]**.

Voltage range	Code [bits 12-11]
Max. 300 V	00
Max. 520 V	01



Refer to «EMN software release note « (paragraph 7).

4.2.11 Software Version (register 50)

The software version reflects the major release number of the EMN software

The MSB of this register contains the version number.

The LSB of this register contains the revision number.

4.2.12 Status Word (register 51)

The status of the EMN can be read from a read-only register.

Bit	Status Description
0	Set when synchronized to 50/60Hz
1	Set if a checksum error has been detected at power-up
2,3,4,5,6,7	Not Used
8	Internal use only
9	Internal use only
10	Not Used
11	Internal use only
12	Internal use only
13,14,15	Not Used

4.2.13 Command Word (register 52)

The EMN is able to execute commands after a write to a command **word**, which is mapped to a **R/W** register.

Setting a bit in the command **word** executes the command.

Bit	Command
0	Reset Meter. This resets the device counters and the Interval counters
7	Place EMN in direct serial communication mode. Used during manufacturing. Do not place EMN in this mode, otherwise the EMN will not be able to communicate via radio module. If this is done, turn device OFF and ON again to reset the mode to normal radio communication
1,2,3,4,5,6,8,9,10,11,12,13,14,15	Not Used / Ignored

Reset Meter

This command resets the energy counters to zero in both RAM and non-volatile RAM.

This command does not affect the reporting interval values.

Direct serial word

This able radio-communication to restore radio-communication mode, power cycle EMN (Switch OFF, then ON).

4.2.14 Zero Power Detection (register 70)

This register has been added in EMN software version 2.0 in order to define a threshold below which any power value will be considered as noise measurement and to ensure that when there is no load on sensors, the EMN exactly counts 0.

This register defines a number of LSB, between 0 and 10, with default value 3 (values below 3 are not recommended).

1 LSB = 8.8 / Scaling factor for Intvl Energy (Watt).

For instance, considering a EMN-100 device.

1 LSB = 8.8 / 3.2 = 2.75 Watt and default power threshold is 8.25 Watt (3 x 2.75).

In case of 'No Load' detection, Active, Reactive, Apparent Energy registers and also Maximum Current registers are set to 0.

4.2.15 Hop count (register 201)

This register reports the number of network node hops taken by a packet delivered from the device to the Mesh Gate. A device with a hop count equals to 1 is communicating directly with the Mesh Gate.

For a greater hop count, the First Hop ID (reg. 202) and the Last Hop ID (reg. 203) report the device ID of respectively the first Mesh Node and the last Mesh Node on the path used by a packet to get to the Mesh Gate.

4.2.16 RSSI (register 204)

RSSI value is stored in the first byte of Register 204 (high byte) and can be positive either negative (signed integer).

When negative, it is calculated using 2's complements. The following table shows some examples of RSSI representation:

RSSI value	1st byte of register 204 in decimal	1st byte of register 204 in hex
-10	246	F6
-25	231	E7
-40	216	D8



Notes:

We would suggest RSSI segmentation as follows:

RSSI > -20 strong

-20 > RSSI > -35 good

-35 > RSSI > -45 weak

-RSSI < -45 not acceptable

The second byte of register 204 is the battery voltage raw data, which can be converted into voltage value in decimal as follows:

$$\text{Battery Voltage} = (1.225 \cdot 1023.0) / (\text{blRaw} + 344)$$

where blRaw is the raw value in decimal. For instance, a battery reading of 0x19 (2nd byte of register 204) would be 25 in decimal, then Battery Voltage = $(1.225 \cdot 1023) / (25 + 344) = 3.3961$ V.

4.2.17 Device & Group ID

Device ID and Group ID can be directly read respectively in registers 220 and 221.

They can be modified by registers 347 (Device ID) and 348 (Group ID) .



Note: Group ID high byte must be between 1 and 159.

⚠ WARNING

ALWAYS WRITE TO BOTH REGISTERS 347 & 348 SIMULTANEOUSLY IN ONE WRITE MULTIPLE COMMAND. TO KEEP THE SAME VALUE IN EITHER REGISTER, USE 0X0000 IN WRITE COMMAND FOR THAT REGISTER.

⚠ WARNING

IF GROUP ID HIGH BYTE IS SET TO A NUMBER OUT OF 1.. 159, THE DEVICE WILL BE DEFINITELY LOST FOR THE NETWORK. IN THIS CASE, IT MUST BE SHIPPED BACK TO LEM FOR REPROGRAMMING.

4.2.18 Network Channel

Network Channel can be read in register 224 and overwritten into register 351 by any value between 11 and 26.

⚠ WARNING

MODIFYING CHANNEL NUMBER MAY LEAD TO MAKE THE DEVICE INVISIBLE BY THE NETWORK.

4.2.19 Sampling Interval

This interval time is the maximum period for hard bit to be sent by any node, if no data streams, in order to declare the device is still online. Value is given in tenths of seconds from 0 to 65535 (65535 = 109 minutes), read from register 222 and written into register 349.

EMN has default value of 30s (value 300 read back)



Note: Sampling Interval must be longer than Broadcast Interval (see chapter 4.5.5).

4.3 Mesh Gate

4.3.1 MG 6424 Register table

The registers hold information about the gateway as well as the MeshScape network

Modbus register	Description	Type	Read/Write
0	Group ID	U16	R
1	Mesh Gate device ID	U16	R
2~17	Online device ID list bitmap (including the Mesh Gate ID)*	U16	R
18	Total online device count	U16	R
19~20	UTC time stamp **	U16	R/W
37	Mesh Gate firmwave version major number	U16	R
38	Mesh Gate firmwave version minor number	U16	R
39	Mesh Gate firmwave version revision number	U16	R
40~44	Reserved for future use	U16	
45	Radio channel number (11~26)	U16	R/W

* For (Active Endnode Device List Bit Map), in order to get the list of online devices, first, read the gateway registers holding the EMN slave addresses (2 .. 17) and place them into an array. Then cycle through each bit and test it for "1" to see if it's online.

```
// read the Mesh Gate data for EMN ids
read_gw_data ();
for (i = 0 ; i < 16; i++) // i is the bitmap register index
{
    for (j = 0 ; j < 16; j++) // j is the bitmap bit index
    { // Test the bit
        if ((EMN_map [ i ] & (1 << j)) != 0) // EMN_map [] = regs 2 - 17 of the MG
        {
            // identify the Modbus address : the first reg-map holds the MSW
            mbus_ adr = 15 - i ) * 16 + j ;
            if ( mbus-adr < 247 ) // only slave adr < 247 are used by WILEM
            ...
        }
    }
}
```

Each bit of the 16 registers corresponds to a Modbus slave address. The Modbus address is mapped to bit number as follows:

Examples:

- EMN N° 25: register 16, bit 9 = 1
- EMN N°16: register 16, bit 0 = 1

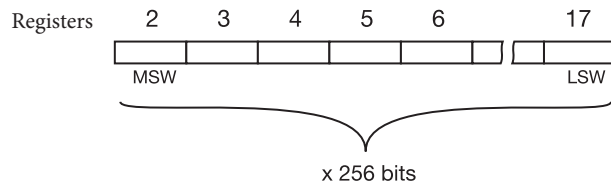

** 32-bits value, R/W, Volatile MN and EMN will be synchronized with this value (MG)
 Write the time value in this register
 Mesh Gate UTC time registers: 19 (MSW) and 20(LSW). Concatenate to have a 32-bit UTC value.

4.3.2 MG 6424 Network Channel modification

The MG 6424 allows the channel modification through the ModBus register #45.

This function replaces the former procedure using the MeshScape Programmer application.



Thanks to the agility capability for all MeshScape devices, you only need to modify this parameter for the Mesh Gate. All Slaves devices (Mesh Nodes and End Nodes) will then scan for Mesh Gate and synchronize on the same channel.

4.3.3 Setting of Mesh Gate Network Time

The Mesh Gate holds the reference time for the entire network.

Mesh Nodes and EMNs will synchronize their internal RTCs after power-up, then at periodic intervals (2-4 minutes).

The initial synchronisation can take up to 6 minutes. Depending on the network configuration /number of hops from Mesh Gate to EMN.

The Mesh Gate is not equipped with a battery, so the internal time is not kept when power is removed. It is thus necessary to set the Mesh Gate time immediately after power-up of the Mesh Gate.

Since the time drift can be up to several seconds/day, synchronizing the Mesh Gates time periodically with the Master-applications time is necessary.



WARNING

WHEN SETTING THE TIME IN THE MESH GATE, BOTH UTC REGISTERS NEED TO BE WRITTEN IN ONE COMMAND.

The ongoing recording intervals in the EMNs will be disrupted by a change of the Mesh Gate time.

4.4 Network

4.4.1 Modbus Interface

The Wireless Mesh Network uses the Modbus RTU (Remote Terminal Unit) framing mode.



ASCII mode is not supported.

The gateway can act in two ways:

- Modbus Slave with Mesh Gate data
- EMN Slave proxy with EMN data

4.4.1.1 Mesh Gate Modbus slave

Indicate that this slave has address 247 before the command list.

The following commands are known:

- Read Holding Registers (0x03)
- Write Multiple Registers (0x10)
- Read Device Identification (0x2B/0x0E)

4.4.1.2 EMN Modbus slave

The Mesh Gate responds to Modbus requests with Modbus slave addresses corresponding to a EMN. Available Modbus commands are:

- Read Holding Registers (0x03)
- Write Multiple Registers (0x10)



Response of a write command will always be “acknowledge” response.

To verify if a write command is successful, poll the register that written to.

To the notice could be added the following:

From the Modbus Application Protocol:

Exception code 05 Acknowledge:

Specialized use in conjunction with programming commands.

The server (or slave) has accepted the request and is processing it, but a long duration of time will be required to do so. This response is returned to prevent a timeout error from occurring in the client (or master). The client (or master) can next issue a Poll Program Complete message to determine if processing is completed.

The format of this response is as follows:

EMN slave adr: 0xXX

Error code: 0x90

Exception code: 0x05

CRC_hi: 0xYY

CRC_lo: 0xZZ

4.4.2 Network Identification of EMN

Each of the EMNs has a unique **MeshScope 16-Bit ID** (DID) which is printed on the EMN in the form of **[High Byte]. [Low Byte]**.

As the Modbus supports only 8-Bit addresses, only the **Low Byte** of the MeshScope address is used for Modbus communications.

4.4.3 Modbus Communication



For more information about Modbus protocol, see: www.modbus.org

The EMNs are seen as Modbus slaves through the Mesh Gate.

The maximum size of a **Modbus RTU** frame is 256 bytes.

A Modbus request has the following general format.

Description	Slave Address	Function Code	Request Data	CRC
Byte Count	1	1	4 (typical, see below)	2 (LSB MSB)

4.4.3.1 Read Holding Registers (Function code 0x03)

Master Request Format

Description	Slave Address	Function Code	Request Data	CRC
Hex	0xID	0x03	0xXX ... 0x7D	0xLSB 0xMSB

Slave Request Format

Description	Slave Address	Function Code	Request Data	CRC
Hex	0xID	0x03	0xXX 0xYY	0xLSB 0xMSB

The following is a Modbus master read request packet. A request is referred to as a packet sent from the Modbus master application to the gateway slave. This has a function code value of 0x03.

The **Request Data** includes a 2 byte starting address offset value and a 2 byte length value specifying the length of data to be returned in a 16 bit word (number of Holding Registers, 1 to 125 (0x7D)).

4.4.3.2 Examples

Read the frequency from EMN with ID 63

- Modbus address0x3F
- Starting register 0x1B (register 27 decimal)
- Length.....0x01

[3F 03 00 1B 00 01 F0 D3]

Read all IRMS and URMS values from EMN with ID 63

- Modbus address0x3F
- Starting register 0x2B (register 43 decimal)
- Length.....0x06

[3F 03 00 2B 00 06 B1 1E]

4.5 Software utilities

4.5.1 Addressing a Node

All devices communicating in the same Mesh network must have the same Channel number (same frequency), same Group ID and a different address given by the device ID low byte. They are delivered from factory with default Channel number 11 and Group ID 111.111

The nodes are also already addressed at factory.

However, in a existing network, it can be necessary to change the address of the node if the same address is already set to another device.

Most often, this is the only parameter you may need to change (refer to chapter 4.5.4).

4.5.2 Managing several Mesh networks

Rarely, in specific configurations, several networks are installed in the same site within radio range of each other. In such case, each network must be isolated and in order to prevent cross-talk between the networks, they should have:

- different Group ID and different channel;
- different Device IDs for all devices in the site; particularly, Mesh Gate and Mesh Node devices must have unique ID. So, regarding the Mesh Gate, this can imply to change the ID high byte (as low byte is always 247) by adding +1. For instance, all Mesh Gate devices initially identified with 190.247, will be reprogrammed in 190.247, 191.247, 192.247, and so on

If the Group ID of all devices must be changed, change this parameter first on all End nodes and Mesh nodes devices with MeshScape Monitor (see chapter 4.5.4). Keep in mind the devices must communicate with the Mesh Gate (declared online) to be updated.

At the very end, change the Mesh Gate Group ID with MeshScape Programmer tool (refer to chapter 4.5.5).

If the network channel must be changed, thanks to the agility capability for all MeshScape devices, this parameter requires to be reprogrammed only for the Mesh Gate. All Slave devices (MeshNodes and End Nodes) will then scan for Mesh Gate and synchronize on same frequency.

4.5.3 Channel choice

If Meshscape wireless devices share radio space with other wireless networks around 2.4 GHz, it may be required to modify the default channel number.



Note: Thanks to the agility capability for all MeshScape devices, you only need to modify this parameter for the Mesh Gate. All Slaves devices of a particular Group ID (Mesh Nodes and End Nodes) will then scan for Mesh Gate and synchronize on the same channel.

⚠ WARNING

CHANGING THE CHANNEL OF A WHOLE NETWORK BY USING THE CHANNEL AGILITY CAPABILITY MAY TAKE SEVERAL MINUTES BEFORE THE COMPLETE SYNCHRONIZATION, ACCORDING TO NETWORK SIZE AND TOPOLOGY.

4.5.4 Node Device ID & Group ID change

Modifying Node Device ID and Group ID can be performed with MeshScope Monitor (see §3.5.3)

- A Select **Utilities**, then the command **"Update Network Identity"**.

 The window beside is displayed.

- B Enter the new ID of the node in the field **(2)**.

- C Enter the new Group ID of the node in the field **(3)** if required.

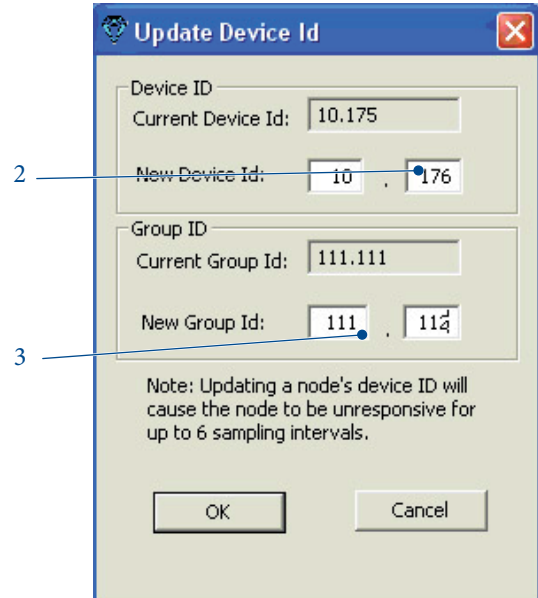

Fig. 4-1: Update Device ID

 **Note:** Group ID high byte must be between 1 and 159.

WARNING

GROUP ID MODIFICATION MUST BE DONE WITH SPECIAL CARE, ONLY IF REQUIRED: MODIFYING THE GROUP ID OF A NODE WILL THEN MAKE IT INVISIBLE ON THIS NETWORK.

4.5.5 MG 6424 Reprogramming Group ID, Device ID and Channel

- A Switch the MG 6424 to Standard (MASC) mode and use RS 232 mode (3.5.2.1 paragraph)
- B Open the application MeschScope Plus Programmer (release 3.00 or later)
- C Select «OB Gateway» in the Device Select Box (1)
- D Select the right programming Port (5)
- E Disable the Program Flash selection (un-tick)
- F To reprogram the Group ID, in Group & Device ID section, select Enable, then enter new Group ID value in field (2). Take care that the device ID, which is printed on the Mesh Gate back side, must also be specified in field (4).
- G To reprogram the Radio Channel number, in Radio Configuration section, select Enable then select the new selected value in field (3). Let the Channel Search Agility Enable.
- H Click on the «Program» soft key (6)

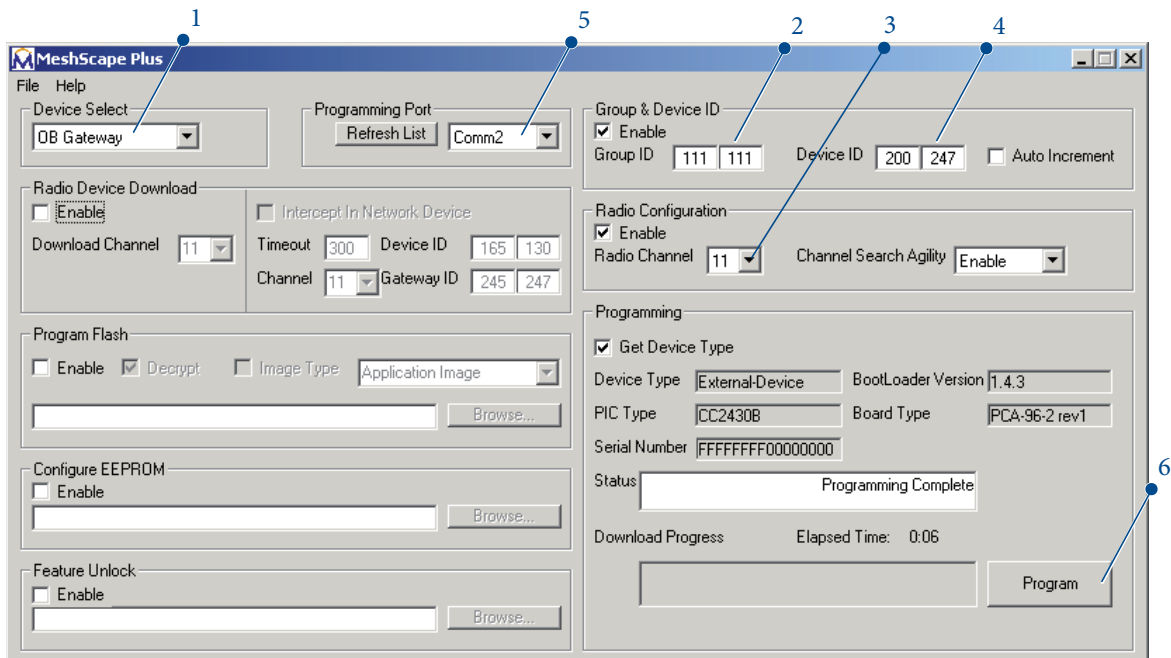

Fig. 4-2: MeshScope Programmer

 **Note:** Group ID high byte must be between 1 and 159.

4.5.6 Broadcast and Sampling Interval

4.5.6.1 Introduction

Considering the RF communication, by default, EMN module sends a packet every 20 seconds. As 3 packets are required to update all Modbus registers, then you get information refreshed every minute.

Now, in case of large network or network with bottleneck, if this interval, time between two packets transmission, is too short, wireless network will get flooded and some data packets won't get to the gateway.

The minimal interval time, in seconds, can be calculated using following formula, **valid for worst case situation**:

$$\text{Min Interval (sec)} = 2 \times \text{MN} + \text{EN}$$



Notes

MN: Amount of Mesh Node modules

EN: Amount of End Node modules (EMN, Wi-Pulse, ...)

In a suitable environment, as a Star Mesh Network topology, this result can be slightly reduced.

This parameter, called Broadcast interval, is saved in EEPROM.

The End Node radio sub-module has its own interval time, called Sampling interval, which is the maximum period for hard bit to be sent, if no data streams, in order to declare the device is still online.

This value must be higher than the broadcast interval, previously calculated. By default, it is set to 30 seconds for EMN module.

This parameter is reported in Interval row (1) by MeshScope Network Monitor but is written in RAM only, so you need to rewrite it in case of shutdown. Best solution is the application to periodically overwrite this value.

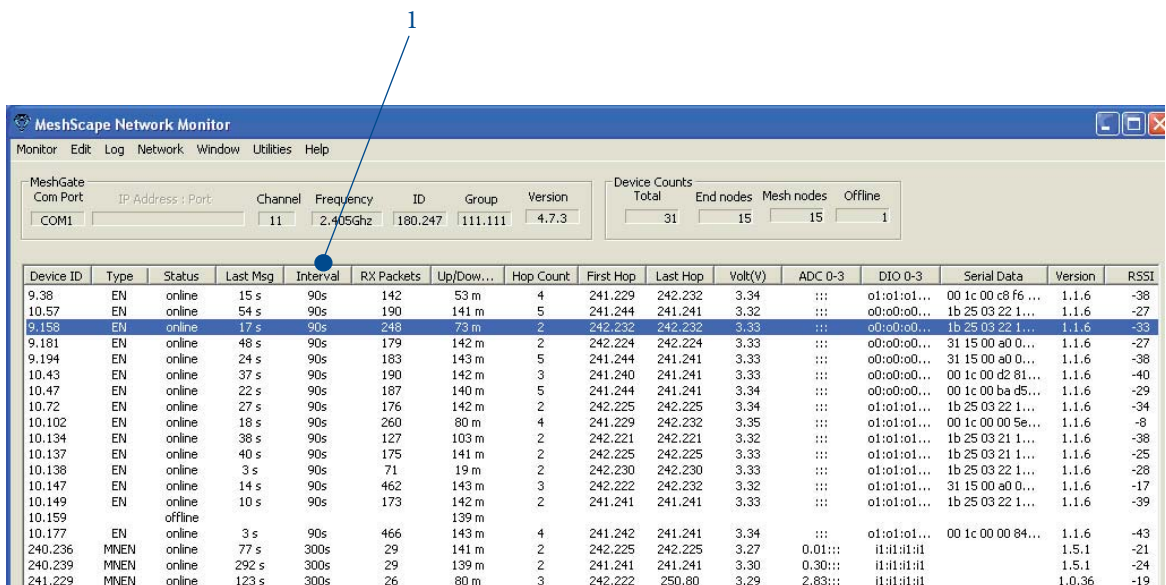

MeshGate							Device Counts								
Com Port	IP Address + Port	Channel	Frequency	ID	Group	Version	Total	End nodes	Mesh nodes	Offline					
COM1		11	2.405Ghz	180.247	111.111	4.7.3	31	15	15	1					
Device ID	Type	Status	Last Msg	Interval	RX Packets	Up/Dow...	Hop Count	First Hop	Last Hop	Volt(V)	ADC 0-3	DIO 0-3	Serial Data	Version	RSSI
9.38	EN	online	15 s	90s	142	53 m	4	241.229	242.232	3.34	...	01:01:01...	00 1c 00 c8 f6 ...	1.1.6	-38
10.57	EN	online	54 s	90s	190	141 m	5	241.244	241.241	3.32	...	00:00:00...	1b 25 03 22 1...	1.1.6	-27
9.158	EN	online	17 s	90s	248	73 m	2	242.232	242.232	3.33	...	00:00:00...	1b 25 03 22 1...	1.1.6	-33
9.181	EN	online	48 s	90s	179	142 m	2	242.224	242.224	3.33	...	00:00:00...	31 15 00 a0 0...	1.1.6	-27
9.194	EN	online	24 s	90s	183	143 m	5	241.244	241.241	3.33	...	00:00:00...	31 15 00 a0 0...	1.1.6	-38
10.43	EN	online	37 s	90s	190	142 m	3	241.240	241.241	3.33	...	00:00:00...	00 1c 00 d2 81...	1.1.6	-40
10.47	EN	online	22 s	90s	187	140 m	5	241.244	241.241	3.34	...	00:00:00...	00 1c 00 ba d5...	1.1.6	-29
10.72	EN	online	27 s	90s	176	142 m	2	242.225	242.225	3.34	...	01:01:01...	1b 25 03 22 1...	1.1.6	-34
10.102	EN	online	18 s	90s	260	80 m	4	241.229	242.232	3.35	...	01:01:01...	00 1c 00 00 5e...	1.1.6	-8
10.134	EN	online	38 s	90s	127	103 m	2	242.221	242.221	3.32	...	01:01:01...	1b 25 03 21 1...	1.1.6	-38
10.137	EN	online	40 s	90s	175	141 m	2	242.225	242.225	3.33	...	01:01:01...	1b 25 03 21 1...	1.1.6	-25
10.138	EN	online	3 s	90s	71	19 m	2	242.230	242.230	3.33	...	01:01:01...	1b 25 03 22 1...	1.1.6	-28
10.147	EN	online	14 s	90s	462	143 m	3	242.222	242.232	3.32	...	01:01:01...	31 15 00 a0 0...	1.1.6	-17
10.149	EN	online	10 s	90s	173	142 m	2	241.241	241.241	3.33	...	01:01:01...	1b 25 03 22 1...	1.1.6	-39
10.159	EN	offline				139 m									
10.177	EN	online	3 s	90s	466	143 m	4	241.242	241.241	3.34	...	01:01:01...	00 1c 00 00 84...	1.1.6	-43
240.236	MNEN	online	77 s	300s	29	141 m	2	242.225	242.225	3.27	0.01:...	11:11:11:11		1.5.1	-21
240.239	MNEN	online	292 s	300s	29	139 m	2	241.241	241.241	3.30	0.30:...	11:11:11:11		1.5.1	-24
241.229	MNEN	online	123 s	300s	26	80 m	3	242.222	250.80	3.29	2.83:...	11:11:11:11		1.0.36	-19

Fig. 4-3: MeshScope Network Monitor screen

4.5.6.2 Reprogramming procedure

The calculated value, minimal Broadcast interval, specific to each EMN is part of the internal firmware and can be modified by a Modbus register (#297).

Remind:

Available Modbus commands are:

- Write Multiple registers (function code 0x10)
- Read Holding registers (function code 0x3).

They must be sent with Modbus Slave addresses corresponding to the EMN ID.

You must modify this setting for each EMN installed in the Mesh network.

- A** Set broadcast interval value (seconds) in register #297 (0x3c = 60 sec).
Wait until this value has been updated (same register).
- B** Set sampling interval value in tenth of seconds (900 or 0x384 for 90s) in register #349.
Read back this value in register #222.



Note: For EMN software releases prior to V2.0, register #297 is protected and EMN device requires to receive a password first. Set password to '0x1234'(decimal value 4660) in register #298 and wait until this value has been updated by polling this register. EMN software version is printed on the front label and can be read from Modbus register #50.

This page is intentionally left blank

5. COMPLEMENTARY PRODUCTS

Several wireless products are available to be integrated into the Mesh network in order to complete measurements of different parameters:

- **Wi-Pulse** Pulse Metering
Wi-Pulse is used to wirelessly monitor and communicate pulse-output signals from meters such as water and fuels.
- **Wi-Zone** Temperature and Relative Humidity Metering
Internal and external temperature and relative humidity sensing is provided by Wi-Zone.
- **Wi-Temp** Relative Temperature Sensing
Wi-Temp measures temperature conditions in various commercial, residential and industrial environments.

In battery powered end nodes, actual battery pack might obstruct the radio signal. If you are using such devices in your network, always consider position of the battery pack in relation to radio signal path.

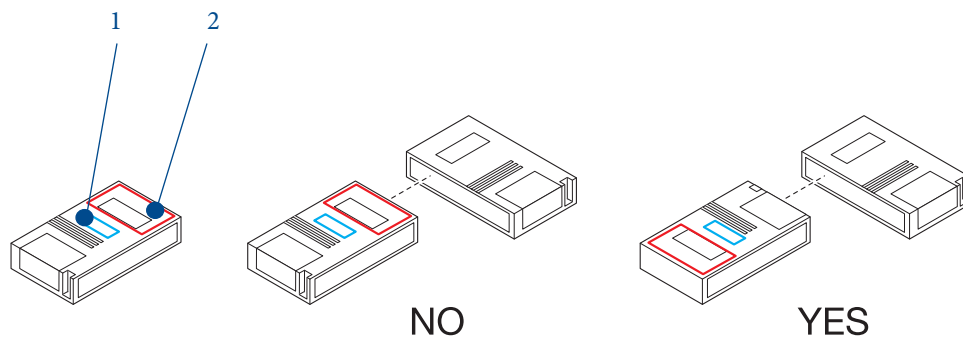

Fig. 5-1: RF link and battery pack position

1. Radio antenna
2. Battery pack

5.1 Wi-Pulse

5.1.1 Description

1. Counter #1 (RJ14)
2. Counter #2 (RJ14)
3. Alternative source power
4. Includes 3xAA alkaline batteries



Note: Wi-pulse requires a specific tool to remove the four screws on backside in order to replace the batteries pack.

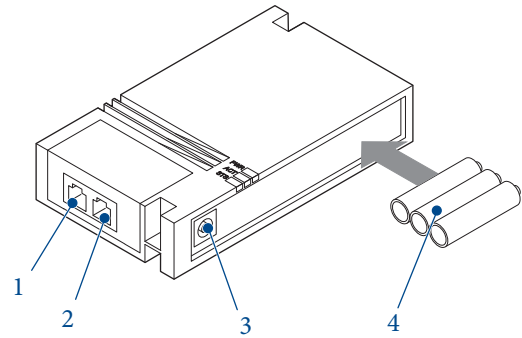

Fig. 5-1: Wi-Pulse

Wi-Pulse is a dual input pulse counter which has been designed with Wi-LEm concept in order to be compliant with existing EMN product. In particular, Wi-Pulse is able to provide 2 types of registers:

- **Counter register:** to accumulate pulses from first power-on until end of life of the Wi-Pulse .
- **Interval register:** to accumulate pulses during a given and settable (5,6,10,12,15,20 and 30 minutes) interval of time.

When the module is powered with internal battery, the PWR LED is only ON during “a short time” when the module is switched ON (internal ON/OFF switch under the lift-off cover), then all LEDs are OFF.

When the unit is line powered, detection is automatically done and the PWR LED is permanently ON; the STS and ACT LEDs behavior is as follows.

- **One parent (one route to Mesh Gate):** STS ON
- **Two parents (or more):** both STS and ACT ON
- **No parent (no communication with Mesh Gate):** STS and ACT OFF.



WARNING

FOR GAS METER USE, AN ADDITIONAL INTRINSIC SAFETY BARRIER IS NEEDED.

5.1.2 Modbus Register Table

Modbus Register	Description	Remarks	R/W
28	Date time stamp minutes (MSB) and seconds (LSB)	Time stamp in data packet is converted into wall time by Mesh Gate and stored.	
29	Date time stamp day (MSB) and hour (LSB)		
30	Date time stamp year (MSB) and month (LSB)		
160	Cumulative Pulse count (high 16-bit) for meter #1	Pulse count stored in two registers; reset by writing 0xAA00 in register 364	R
161	Cumulative Pulse count (low 16-bit) for meter #1		R
162	Cumulative Pulse count (high 16-bit) for meter #2	Pulse count stored in two registers; reset by writing 0x00AA in register 364	R
163	Cumulative Pulse count (low 16-bit) for meter #2		R
164	Pulse count per interval for meter #1	Pulse count over an interval as defined in register 166	R
165	Pulse count per interval for meter #2		
166	Data reporting & accumulation interval (wall time synchronized)	This register stores data reporting interval in minutes; this is also the interval for pulse accumulation with available values: 1 (5 min), 2 (6 min), 3(10 min), 4 (12 min), 5 (15 min), 6 (20 min), 7 (30 min), 8 (1 min). Write value to register 363.	R
204	RSSI (MSB) & Supply voltage (LSB)	First byte stores RSSI (signed 8 bit, using 2's complement); second byte stores supply voltage BIRaw then Volt (V)=(1.225*1023)/(BIRaw+344) For more details, see chapter 4.2.16	R
363 ¹⁾	Data reporting & accumulation interval (wall time synchronized)	This register stores data reporting interval in minutes; this is also the interval for pulse accumulation with available values: 1 (5 min), 2 (6 min), 3(10 min), 4 (12 min), 5 (15 min), 6 (20 min), 7 (30 min), 8 (1 min). Read value back from register 166.	W
364	Cumulative counter reset for meters #1 & #2	0xAA00 resets meter #1 cumulative pulse counter 0x00AA resets meter #2 cumulative pulse counter Meter #1 returns 0x5500 to confirm reset Meter #2 returns 0x0055 to confirm reset	W/R

⚠ WARNING

¹⁾ WI-PULSE DELIVERED WITH INTERVAL TIME SET TO 1 MIN FOR COMMISSIONING. MUST THEN BE CHANGED TO 5 MIN OR MORE.

5.2 Wi-Zone

5.2.1 Description

1. Sensor location
2. Alternative source power
3. Includes 3xAA alkaline batteries



Note: Wi-Zone requires a specific tool to remove the four screws on backside in order to replace the batteries pack.

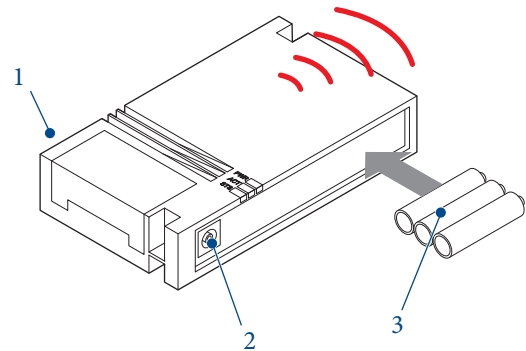

Fig. 5-2: Wi-Zone

Wi-Zone measures local temperature and relative humidity and is compliant to other Mesh products, with EMN format time stamp.

When the module is powered with internal battery, the PWR LED is only ON during “a short time” when the module is switched ON (internal ON/OFF switch under the lift-off cover), then all LEDs are OFF.

When the unit is line powered, detection is automatically done and the PWR LED is permanently ON; the STS and ACT LEDs behavior is as follows.

- **One parent (one route to Mesh Gate):** STS ON
- **Two parents (or more):** both STS and ACT ON
- **No parent (no communication with Mesh Gate):** STS and ACT OFF.

5.2.2 Modbus Register Table

Modbus Register	Description	Remarks	R/W
28	Date time stamp minutes (MSB) and seconds (LSB)	Time stamp in data packet is converted into wall time by Mesh Gate and stored.	R
29	Date time stamp day (MSB) and hour (LSB)		
30	Date time stamp year (MSB) and month (LSB)		
107	Wi-Zone temperature	This register stores the temperature; the value corresponds to current temperature, in °F, multiplied by 10.	R
108	Wi-Zone humidity	This register stores the percentage of measured relative humidity, multiplied by 10; e.g 300 means 30% relative humidity.	R
166	Data reporting interval	This register stores data reporting interval in minutes: 1 (5 min), 2 (6 min), 3(10 min), 4 (12 min), 5 (15 min), 6 (20 min), 7 (30 min), 8 (1 min). Write value to register 363.	R
204	RSSI (MSB) & Supply voltage (LSB)	First byte stores RSSI (signed 8 bit, using 2's complement); second byte stores supply voltage BIRaw then Volt (V)=(1.225*1023)/(BIRaw+344) For more details, see chapter 4.2.16	R
363 ¹⁾	Data reporting interval	This register stores data reporting interval in minutes: 1 (5 min), 2 (6 min), 3(10 min), 4 (12 min), 5 (15 min), 6 (20 min), 7 (30 min), 8 (1 min). Read value back from register 166.	W

⚠ WARNING ¹⁾ WI-ZONE DELIVERED WITH INTERVAL TIME SET TO 1 MIN FOR COMMISSIONING. MUST THEN BE CHANGED TO 5 MIN OR MORE.

5.3 Wi-Temp

5.3.1 Description

4. Temperature probe #1 (RJ14)
5. Temperature probe #2 (RJ14)
6. Alternative source power
7. Includes 3xAA alkaline batteries

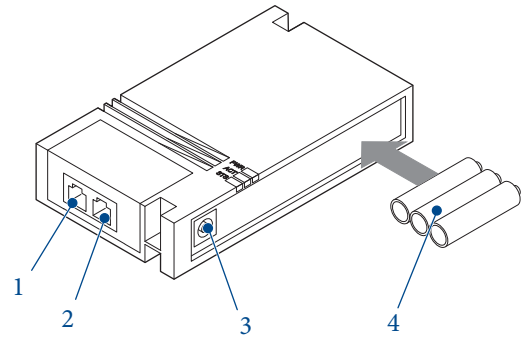

Fig. 5-3: Wi-Temp



Note: Wi-Temp requires a specific tool to remove the four screws on backside in order to replace the batteries pack.

By adding up to two external probes, Wi-temp measures temperature conditions in various commercial, residential and industrial environments and is compliant to other Mesh products, with EMN format time stamp.

When the module is powered with internal battery, the PWR LED is only ON during «a short time» when the module is switched ON (internal ON/OFF switch under the lift-off cover), then all LEDs are OFF.

When the unit is line powered, detection is automatically done and the PWR LED is permanently ON; the STS and ACT LEDs behavior is as follows.

- **One parent (one route to Mesh Gate):** STS ON
- **Two parents (or more):** both STS and ACT ON
- **No parent (no communication with Mesh Gate):** STS and ACT OFF.

5.3.2 Modbus Register Table

All register values are UINT16, unless otherwise stated

All temperature values in registers are in deg F, all temperature data represent actual values multiplied by 10.

Modbus Register	Description	Remarks	R/W
28	Date time stamp minutes (MSB) and seconds (LSB)	Time stamp in data packet is converted into wall time by Mesh Gate and stored.	R
29	Date time stamp day (MSB) and hour (LSB)		
30	Date time stamp year (MSB) and month (LSB)		
91	Wi-Temp temperature for channel #1	This register holds 1st channel temperature; the value corresponds to actual temperature, in °F, multiplied by 10.	R
92	Wi-Temp temperature for channel #2	This register holds 2nd channel temperature; the value corresponds to actual temperature, in °F, multiplied by 10.	R
105	UTC (UINT32, high order 16 bits)	Universal Time Coordinated. Number of seconds from January 1st, 1970	R
106	UTC (UINT32, low order 16 bits)		
166	Data reporting interval (wall time synchronized)	This register stores data reporting interval in minutes with available values: 1 (5 min), 2 (6 min), 3 (10 min), 4 (12 min), 5 (15 min), 6 (20 min), 7 (30 min), 8 (1 min). Write value to register 363.	R
204	RSSI (MSB) & Supply voltage (LSB)	First byte stores RSSI (signed 8 bit, using 2's complement).	R
363 ¹⁾	Data reporting interval (wall time synchronized)	This register stores data reporting interval in minutes with available values: 1 (5 min), 2 (6 min), 3 (10 min), 4 (12 min), 5 (15 min), 6 (20 min), 7 (30 min), 8 (1 min). Read value back from register 166.	W

⚠ WARNING

¹⁾ WI-TEMP DELIVERED WITH INTERVAL TIME SET TO 1 MIN FOR COMMISSIONING. MUST THEN BE CHANGED TO 5 MIN OR MORE.

This page is intentionally left blank

6. TROUBLESHOOTING

Detected problems	Causes	Solution
No communication (MeshScope Monitor)	EMN or Mesh Node powered off	Check external power for Mesh Node and L1 powered for EMN
	EMN blinking twice and/or Mesh Node LED "STS" OFF	Check same GID for all modules. Add Mesh Node or move existing ones. Check first Mesh nodes close to Mesh Gate
Communication OK but EMN blinking 3 times	EMN not synchronized to 50/60 Hz	Check L1 line at EMN input: frequency (45-65) Hz and voltage above $70V_{rms}$
Network instability (Modules appear & disappear)	Too much traffic because of high number of EMN and Mesh Node	Increase the EMN broadcast/sampling interval $Min\ Intl\ (sec) = 2 * MN + EN$
	External RF perturbation (other network)	Try to relocate Mesh network far from the perturbation or if not possible use a different radio channel
Strange / wrong data (Modbus application)	Nodes (EMN, MN) with same ID	Change Device ID
	EMN installation	Voltage connection missing or wrong phases allocation
	Software interface	Check applied scaling factors
Counter values stuck	Intermittent communication loss	Confirm with time-stamp. If still incrementing, no communication loss but no more consumption
Spurious Counter values to 0	Mesh Gate register reset (if no Modbus access during 30 min.)	Don't consider Null value from counters in Energy calculation (difference)
Negative active energy on Intl registers or decrementing for counters	Current transducer or Rogowski coil mounted in the wrong direction	On both modules, the arrow indicates the current flow.
Negative reactive values	Can be normal as $Q\ (VAR) = U_{eff} \cdot I_{eff} \cdot \sin \varphi$, φ current / voltage dephasing	$\sin \varphi < 0$ if capacitive load $\sin \varphi > 0$ if inductive load $\sin \varphi = 0$ if pure resistive load

⚠ WARNING IN CASE OF ESTABLISHED FAILURE OF THE EMN MODULE ONLY LEM'S ASS (AFTER SALES SERVICE) IS AUTHORIZED TO REPAIR IT.







This page is intentionally left blank

7. EMN SOFTWARE RELEASE NOTE

Software release	Issue description	Workaround	Bug fixed with release
EMN_CT V1.0 EMN_RT V1.1	Communication from EMN locked: data streams not refreshed (very rarely)	Resetting EMN (power cycle) or sending a command as writing Recording Interval Time register #53, unlocks communication	EMN_CT V1.02 EMN_RT V1.11
EMN_CT V1.0, V1.02 EMN_RT V1.1, V1.11	Wrong date stamp (day +1) every year following a leap year	Correction might be done by the application software. Contact LEM Support for more details on procedure.	V2.0
V2.0	Wrong EEPROM saving sequence (very rarely) with one phase only use	Resetting EMN (power cycle) until correct LED blinking	V2.01
V2.01	Voltage range values in configuration register (#59) not available. LED status modification		V2.02

This page is intentionally left blank

8. GLOSSARY AND SYMBOLS

- **EMN** Energy Meter Node
- **RTC** Real Time Clock
- **UTC** Coordinated Universal Time. Number of seconds passed since 1.1.1970
- **Mesh Gate** Gateway that controls the RF network and provides a serial interface for the customer.
- **Mesh Node** RF router/repeater
- **End Node / Node** RF communication module integrated in the EMN
- **Hop Count** Number of network node hops taken by a packet delivered from a node to the Mesh Gate.
 For example: End Node — Mesh Gate = 1 hop,
 End Node — Mesh Node — Mesh Gate = 2 hops
 (each additional Mesh Node will add another hop).
- **Modbus** Communications protocol using RS-232/RS-485 used by the Mesh Gate.
- **SELV** Safety Extra Low Voltage
-  Equipment protected throughout by double isolation or reinforced isolation.
- **CAT III** Measurement category III is for measurements performed in the building installation.
-  «Caution, risk of danger» Documentation must be consulted in all cases where this symbol is marked
-  Caution, risk of electrical shock
-  Do not installed or removed on conductors carrying hazardous 12 V
-  Protective conductor terminal
-  Direct current



Further information and protocol specifications can be found on <http://www.modbus.org>.