

AUTOMOTIVE CURRENT TRANSDUCER FLUXGATE TECHNOLOGY

CAB-SF 1500-000, CAB-SF 1500-001, CAB-SF 1500-004, CAB-SF 1500-005, CAB-SF 1500-006,
CAB-SF 1500-008, CAB-SF 1500-009, CAB 1500-000, CAB 1500-001, CAB 1500-005



Introduction

The CAB transducer family is specially designed for the DC current measurement of the battery packs in electric and hybrid vehicles. The CAB 1500 Family transducer is equipped with electronic mechanisms and software that guarantee a level of reliability that is required by the security concepts of battery management systems.

Features

- Fluxgate transducer technology
- Busbar mounting or panel mounting
- Unipolar +12 V battery power supply
- Output signal: High speed CAN (500 kbps).

	CAN Resistor Termination	Casing Version	Other Comments
CAB-SF 1500-000	4800 Ω	Bus bar	
CAB-SF 1500-001	4800 Ω	Panel mounting	
CAB-SF 1500-004	4800 Ω	Bus bar	Inverted I_p sig
CAB-SF 1500-005	4800 Ω	Bus bar	CAN ID 0x10
CAB-SF 1500-006	120 Ω	Bus bar	
CAB-SF 1500-008	4800 Ω	Bus bar	CAN ID 0x4C2
CAB-SF 1500-009	4800 Ω	Bus bar	
CAB 1500-000	4800 Ω	Bus bar	
CAB 1500-001	4800 Ω	Panel mounting	
CAB 1500-005	4800 Ω	Bus bar	CAN ID 0x226

Special features

- Connector type: Tyco AMP 1473672-1
- Configurable CAN speed
- Configurable CAN ID.

Advantages

- Low offset
- Total error 0.5 % over temperature range: -40 °C to +85 °C
- Full galvanic separation
- Compatible with 800 V applications following IEC60664-1 standard.

Automotive applications

The CAB 1500 Family is designed to run in a vehicle battery pack or in a battery disconnect unit and cannot be used in an environment exposed to water projections or gravel projections. The CAB-SF 1500 is compliant with Functional Safety standard ISO 26262.

The test items used to validate the product are described at the end of the document.

Principle of Fluxgate Transducers

A low-frequency fluxgate transducer is made of a wound core which saturates under low induction.

A current chopper switches the winding's current to saturate the magnetic core alternatively at $\pm B_{max}$ with a fixed frequency. Fluxgate transducers use the change of the saturation's point symmetry to measure the primary current.

Due to the principle of switching the current, all offsets (electric and magnetic) are cancelled.

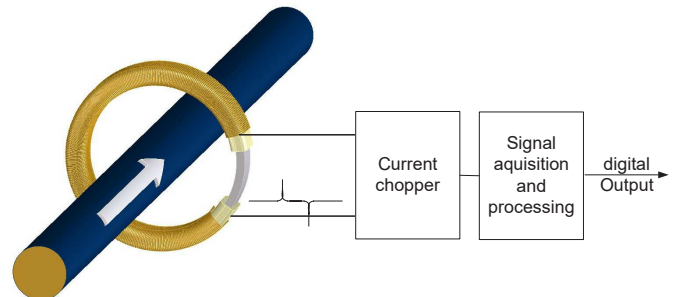

Safety



Caution

If the device is used in a way that is not specified by the manufacturer, the protection provided by the device may be compromised. Always inspect the electronics unit and connecting cable before using this product and do not use it if damaged. Mounting assembly shall guarantee the maximum primary conductor temperature, fulfill clearance and creepage distance, minimize electric and magnetic coupling, and unless otherwise specified can be mounted in any orientation.



Caution, risk of electrical shock

This transducer must be used in limited-energy secondary circuits SELV according to IEC 61010-1, in electric/electronic equipment with respect to applicable standards and safety requirements in accordance with the manufacturer's operating specifications.

Use caution during installation and use of this product; certain parts of the module can carry hazardous voltages and high currents (e.g. power supply, primary conductor).

Ignoring this warning can lead to injury and or/cause serious damage.

This transducer is a build-in device, whose hazardous live parts must be inaccessible after installation.

This transducer must be mounted in a suitable end-enclosure.

Besides make sure to have a distance of minimum 30 mm between the primary terminals of the transducer and other neighboring components.

This transducer is a built-in device, not intended to be cleaned with any product. Nevertheless if the user must implement cleaning or washing process, validation of the cleaning program has to be done by himself.



ESD susceptibility

The product is susceptible to be damaged from an ESD event and the personnel should be grounded when handling it.

Do not dispose of this product as unsorted municipal waste. Contact a qualified recycler for disposal.

Although LEM applies utmost care to facilitate compliance of end products with applicable regulations during LEM product design, use of this part may need additional measures on the application side for compliance with regulations regarding EMC and protection against electric shock. Therefore LEM cannot be held liable for any potential hazards, damages, injuries or loss of life resulting from the use of this product.



Underwriters Laboratory Inc. recognized component

Connector pin out

Primary current direction as below:

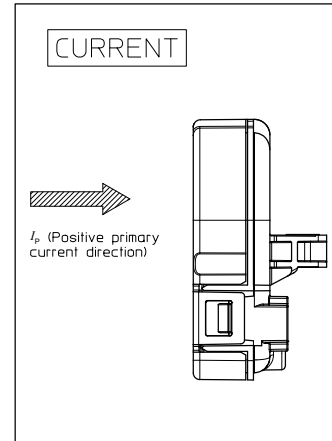
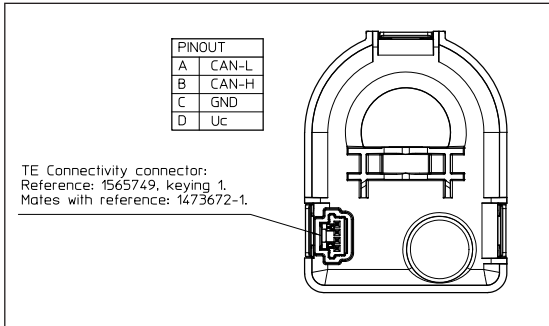

Weight and Recommended screwing torque instruction

Busbar Version

- Weight: 94 g \pm 5 %
- Recommended screwing torque instruction:
 - transducer shall be fixed with M6 fastener
 - tightening torque:
 - screw grade 6.8: 6.6 N·m
 - screw grade 8.8: 7.7 N·m

Panel mounting Version

- Weight: 91 g \pm 5 %
- Recommended screwing torque instruction:
 - transducer shall be fixed with 2 M5 fastener
 - tightening torque:
 - screw grade 6.8: 3.8 N·m
 - screw grade 8.8: 4.4 N·m

Laser Marking

Designation	Datacode	2D matrix content	Text marking area
CAB-SF 1500-000	P = Production center ID YY = Last two digit of the year DDD = Day number of the year CC = Machine ID HH = Hour MM = Minute SS = Second J = Machine jig ID	PYYDDDCCHMMSSJ90.D9.65.000.0	
CAB-SF 1500-001		PYYDDDCCHMMSSJ90.D9.65.001.0	
CAB-SF 1500-004		PYYDDDCCHMMSSJ90.D9.65.004.0	
CAB-SF 1500-005		PYYDDDCCHMMSSJ90.D9.65.005.0	
CAB-SF 1500-006		PYYDDDCCHMMSSJ90.D9.65.006.0	
CAB-SF 1500-008		PYYDDDCCHMMSSJ90.D9.65.008.0	
CAB-SF 1500-009		PYYDDDCCHMMSSJ90.D9.65.009.0	
CAB 1500-000		PYYDDDCCHMMSSJ90.H5.65.000.0	
CAB 1500-001		PYYDDDCCHMMSSJ90.H5.65.001.0	
CAB 1500-005		PYYDDDCCHMMSSJ90.H5.65.005.0	

Absolute ratings (not operating)

Parameter	Symbol	Unit	Specification	Conditions
Over-voltage	U_C	V	24	1 min
Reverse polarity	U_C	V	-18	1 min
Minimum supply voltage	$U_{C\ min}$	V	6	continuous
Maximum supply voltage	$U_{C\ max}$	V	18	continuous
Ambient storage temperature	$T_{A\ st}$	°C	-40 /+105	
Creepage distance	d_{Cp}	mm	12.5	
Clearance	d_{Cl}	mm	12.5	
RMS voltage for AC insulation test	U_d	kV	3.5	50 Hz, 1 min
Insulation resistance	R_{INS}	MΩ	500	1000 V - ISO 16750-2
IP Level			IP41	

Characteristics in nominal range

Parameter	Symbol	Unit	Specification			Conditions
			Min	Typical	Max	
Electrical Data						
Supply voltage	U_C	V	9	13.5	16	$-1500\ A \leq I_p \leq 1500\ A$
			8	13.5	16	$-1000\ A \leq I_p \leq 1000\ A$
RMS current consumption @ $I_p = 0\ A$ ¹⁾	I_C	mA	50	70	100	$8\ V < U_C < 16\ V$, CAN acknowledge
RMS current consumption @ $\pm I_p = 1000\ A$ ¹⁾	I_C	mA	350	400	1000	$8\ V < U_C < 16\ V$, CAN acknowledge
RMS current consumption @ $\pm I_p = 1500\ A$ ¹⁾	I_C	mA	430	500	1400	$9\ V < U_C < 16\ V$, CAN acknowledge
Ambient operating temperature	T_A	°C	-40		+85	
Performance Data						
Primary nominal DC current	I_{PN}	A	-1500		1500	
CAN signal 'CSM_BAT_CURRENT' clamping value		A	-1550		1550	$1550\ A < I_p < \hat{I}_{P\ max}$
Primary withstand peak current (maximum)	$\hat{I}_{P\ max}$	A		1700		
Overload recovery time	t_s	ms		10		When I_p goes back under 1550 A
Frequency bandwidth	BW	Hz		20		With Periodic CAN message @ 10 ms
Start-up time	t_{start}	ms		150		Times after enabled timer/fluxgate, excluded 20 ms additional times for HW initialization/ check
Analog measurement Channel						
Linearity error	ε_L	%		±0.1		At room temperature
Total error: [-1500 A, +1500 A]	ε_{tot}	%		±0.5		Over full temperature range Performances are considered with average value over 20 CAN frames (200 ms); Performances with average value over 10 CAN frames (100 ms), refer to Application Notes
Output noise		mA		±50		With Periodic CAN message @ 10 ms. Peak to peak value. No averaging
Digital measurement channel						
Total error	ε_{tot}	%		±7		With a minimum of ±2 A Typical value after ageing Performances are considered with average value over 20 CAN frames (200 ms)

Note: ¹⁾ Input current peak value refer to Application Notes .

Total error

Analog Channel - Total error from $-40\text{ }^{\circ}\text{C}$ to $85\text{ }^{\circ}\text{C}$:

Performances are considered with average value over 20 CAN frames (200 ms)

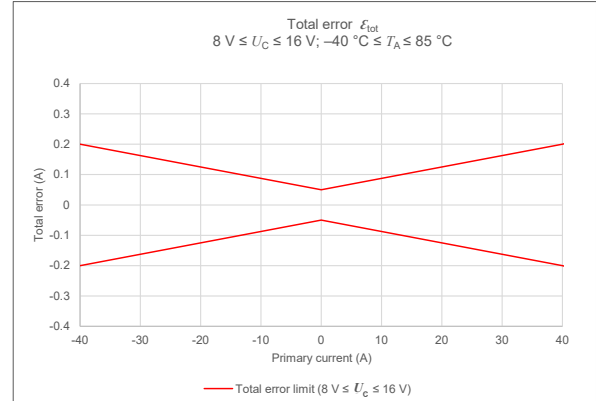
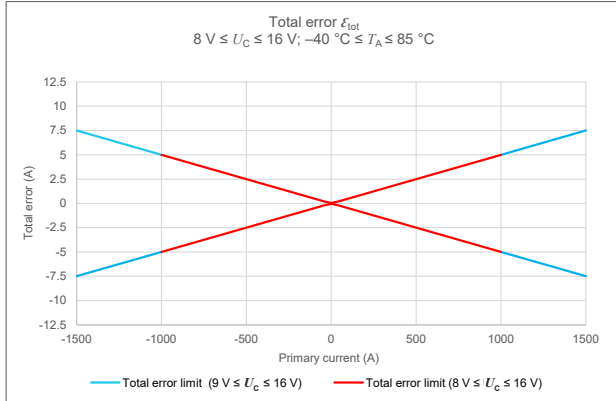

I_p	Total error ($9\text{ V} \leq U_C \leq 16\text{ V}; -40\text{ }^{\circ}\text{C} \leq T_A \leq 85\text{ }^{\circ}\text{C}$)	
	(A)	(%)
-1500	± 7.5	± 0.5
-40	± 0.2	± 0.5
0	± 0.05	-
40	± 0.2	± 0.5
1500	± 7.5	± 0.5

I_p	Total error ($8\text{ V} \leq U_C \leq 16\text{ V}; -40\text{ }^{\circ}\text{C} \leq T_A \leq 85\text{ }^{\circ}\text{C}$)	
	(A)	(%)
-1000	± 5	± 0.5
-40	± 0.2	± 0.5
0	± 0.05	-
40	± 0.2	± 0.5
1000	± 5	± 0.5

External Magnetic Field Influences

The CAB 1500 Family delivers accurate current measurement. However, to ensure its proper functioning and to ensure the current measurement accuracy, it is necessary to comply with rules for setting up in the BMS environment. Thus, some conditions must be respected during the design of the environment of the transducer:

- Primary busbar centering
- Busbar shape
- Contactors position

LEM's recommendations can be found in the application notes available on request. Please contact LEM support team to ensure that your busbars design fits with LEM's design guideline.

Current Ripple Influences

Current ripples on the high voltage DC lines could be induced during power conversion from devices like DC/DC, inverter, on-board charger, and so on.

Current ripples not only negatively impact on the health of li-ion batteries, but also could cause malfunctions of the CAB transducer. The failure mode can manifest itself as a disturbed current measurement due to aliasing effect, leading to internal error when the threshold is exceeded. The malfunctions can be automatically recovered when the ripple current disappears.

Normally the ripple current should be measured and minimized during vehicle system design and development. For proper function of the CAB transducer, the acceptable maximum value of the ripple current should be checked. Please contact LEM support team on the reference values, LEM's recommendations can be found in the application notes available on request.

CAN output specification

- CAN protocol 2.0B
- Bit order: big endian (Motorola)
- CAN oscillator tolerance: 0.27 %
- No sleep mode capability
- 120 Ohm termination resistor to be added externally (except CAB-SF 1500-006), internal CAN impedance = 4.8 kOhm
- CAB-SF 1500-006 integrates 120 Ohm termination resistor inside transducer
- Instruction for CAN modification can be found in the application notes available on request

CAB-SF 1500 CAN message table

- CAB1500_ I_p message overview.
Default frame ID: 0x3C2; transmit period: 10 ms.

CAN Frame Content									
	7	6	5	4	3	2	1	0	
BYTE 0	Sequence Counter I_p				StatusPowerSupply		StatusInternalError	SafetyGoalViolation	
	MSB			LSB	MSB	LSB			
BYTE 1	Analog Current								
	MSB								
BYTE 2	Analog Current								
BYTE 3	Analog Current								
								LSB	
BYTE 4	Digital Curent								
	MSB								
BYTE 5	Digital Curent								
								LSB	
BYTE 6	Reserved								
	MSB							LSB	
BYTE 7	CRC_ I_p								
	MSB							LSB	

• **‘Sequence Counter I_p ’ signal**

- Initialized with 0 and incremented by 1 for every subsequent send request
- When the counter reaches the value 15 (0xF), then restart with 1 for the next send request.

• **‘Status Power Supply’ signal**

CAN Frame Content									
	7	6	5	4	3	2	1	0	
BYTE 0	SequenceCounter I_p				StatusPowerSupply		StatusInternalError	SafetyGoalViolation	
	MSB			LSB	MSB	LSB			

When Power Supply voltage measurement is not available, then ‘Status Power Supply’ = “1 1”

Notes:

- At transducer start-up, if supply voltage < 7.8 V or > 16.2 V, no CAN frame emission
- Status details can be found in the application notes available on request.

• **‘Status Internal Error’ signal**

This flag is set to 1 to inform the BMS about two scenarios:

- Internal hardware abnormal detected (reference voltage, DAC errors and impact from application ripple current, etc)
- Over current detected on the busbar - current above 1600 A. In this use case, the Status Internal Error flag is set to 1 (see details on the next page in ‘Analog Current’ signal section)

• **‘Safety Goal Violation’ signal [SG1: Current Sensing Error]**

In the current range of [-1500 A; -220 A [and] +220 A; +1500 A], if there is more than 20% of difference between analog current level and digital current level --> then Safety Goal Violation = 1

In the current range of [-220 A; 220 A], if there is a gap above 44 A between analog current level and digital current level --> then Safety Goal Violation = 1

Safe State: To provide Safety Goal Violation flag, keep providing current measurement
FTTI: 500 ms

• ‘Analog Current’ signal

Analog measurement of the primary current
 $-1500 \leq I_p \leq +1500$. ‘Analog Current’ signal = I_p . Error = 0.5 %
 $1500 < |I_p| \leq 1550$. ‘Analog Current’ signal = I_p . Error = 1 %
 $-\hat{I}_{p\max} \leq I_p < -1550$. ‘Analog Current’ signal is clamped at -1550 A.
 $+1550 < I_p \leq \hat{I}_{p\max}$. ‘Analog Current’ signal is clamped at $+1550$ A.
 $|I_p| > \hat{I}_{p\max}$. ‘Analog Current’ signal = 0xFFFFF.
 Note: $\hat{I}_{p\max} \approx 1700$ A

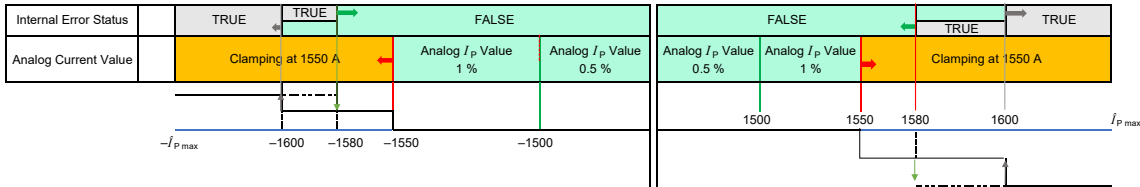

Here below the values for Byte 1, 2 and 3:

I_p	Hex value	MSB			LSB		
		Byte 1	Byte 2	Byte 3	Byte 1	Byte 2	Byte 3
1550.000	97A6B0	97	A6	B0			
1500.000	96E360	96	E3	60			
0.001	800001	80	00	01			
0.000	800000	80	00	00			
-0.001	7FFFFFFF	7F	FF	FF			
-1500.000	691CA0	69	1C	A0			
-1550.000	685950	68	59	50			

• ‘Digital Current’ signal

$-\hat{I}_{P\ max} \leq I_p < -1550$. ‘Digital Current’ signal is clamped at -1550 A. Error = NA

$+1550 < I_p \leq \hat{I}_{P\ max}$. ‘Digital Current’ signal is clamped at $+1550$ A. Error = NA

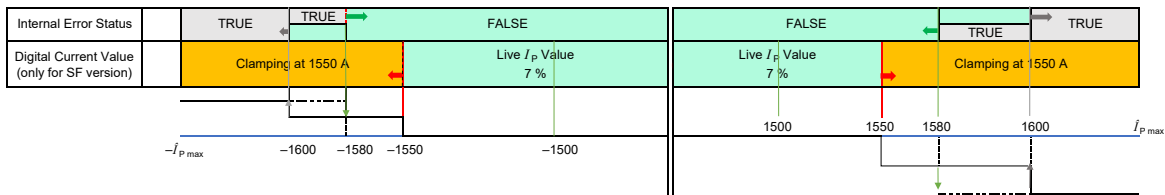

Digital measurement of the primary current, Byte 4 and 5:

I_p	Hex value	MSB	LSB
		Byte 4	Byte 5
1550	860E	86	0E
1500	85DC	85	DC
1	8001	80	01
0	8000	80	00
-1	7FFF	7F	FF
-1500	7A24	7A	24
-1550	79F2	79	F2

• ‘CRC_ I_p ’ signal

8-bit SAE J1850 CRC calculation of the first seven bytes.

CAB 1500 CAN message table

- CAB1500_ I_p message overview.

Default frame ID: 0x3C2; transmit period: 10 ms.

CAN Frame Content								
	7	6	5	4	3	2	1	0
BYTE 0	Sequence Counter I_p				StatusPowerSupply		StatusInternalError	Reserved
	MSB			LSB	MSB	LSB		
BYTE 1	Analog Current							
	MSB							
BYTE 2	Analog Current							
BYTE 3	Analog Current							
								LSB
BYTE 4	Reserved							
BYTE 5	Reserved							
BYTE 6	Reserved							
BYTE 7	CRC_ I_p							
	MSB							LSB

• ‘Sequence Counter I_p ’ signal

- Initialized with 0 and incremented by 1 for every subsequent send request
- When the counter reaches the value 15 (0xF), then restart with 1 for the next send request

• ‘Status Power Supply’ signal

CAN Frame Content								
	7	6	5	4	3	2	1	0
BYTE 0	Sequence Counter I_p				StatusPowerSupply		StatusInternalError	Reserved
	MSB			LSB	MSB	LSB		

When Power Supply voltage measurement is not available, then ‘Status Power Supply’ = “1 1”

Notes:

- At transducer start-up, if supply voltage < 7.8 V or > 16.2 V, no CAN frame emission
- Status details can be found in the application notes available on request.

• ‘Status Internal Error’ signal

This flag is set to 1 to inform the BMS about two scenarios:

- Internal hardware abnormal detected (reference voltage, DAC errors and impact from application ripple current, etc)
- Over current detected on the busbar - current above 1600 A. In this use case, the Status Internal Error flag is set to 1 (see details on the next page in ‘Analog Current’ signal section)

• ‘Analog Current’ signal

Analog measurement of the primary current

$-1500 \leq I_p \leq +1500$. ‘Analog Current’ signal = I_p . Error = 0.5 %

$1500 < |I_p| \leq 1550$. ‘Analog Current’ signal = I_p . Error = 1 %

$-I_{p,max} \leq I_p < -1550$. ‘Analog Current’ signal is clamped at -1550 A.

$+1550 < I_p \leq I_{p,max}$. ‘Analog Current’ signal is clamped at +1550 A.

$|I_p| > |I_{p,max}|$. ‘Analog Current’ signal = 0xFFFFFFFF.

Note: $|I_{p,max}| \approx 1700$ A

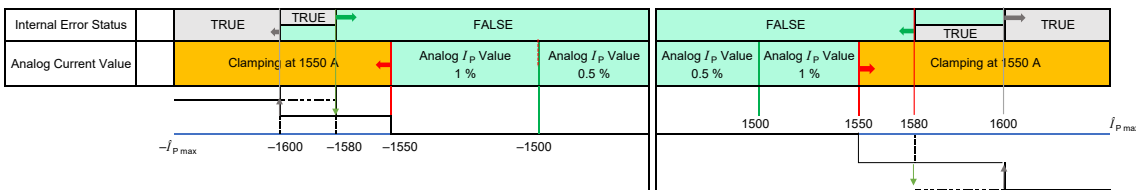

Here below the values for Byte 1, 2 and 3:

I_p	Hex value	MSB	LSB	
		Byte 1	Byte 2	Byte 3
1550.000	97A6B0	97	A6	B0
1500.000	96E360	96	E3	60
0.001	800001	80	00	01
0.000	800000	80	00	00
-0.001	7FFFFFFF	7F	FF	FF
-1500.000	691CA0	69	1C	A0
-1550.000	685950	68	59	50

• ‘CRC_ I_p ’ signal

8-bit SAE J1850 CRC calculation of the first seven bytes.

Applicable standards - Functional Safety - CAB-SF 1500

Safety		
		Safety Manual Table of Contents
Functional Safety (ASIL C compliant)	ISO 26262 (11/2018)	<ul style="list-style-type: none"> 1 DOCUMENT <ul style="list-style-type: none"> 1.1 Applicable documents 1.2 Reference documents 2 GLOSSARY 3 Introduction 4 Assumption 5 Product overview <ul style="list-style-type: none"> 5.1 Purpose 5.2 Type of Current Transducer 5.3 Safety Element out of Context (SEooC) 5.4 Functional Block Diagram 5.5 Mission Profile 6 Safety Measures <ul style="list-style-type: none"> 6.1 Safety Goal allocated to the transducer 6.2 Safety Concept 6.3 Description of the maintenance activities expected from the customer 6.4 Description of the maintenance activities expected from the customer in the case of a failure indicated by the warning and degradation concept 7 Hardware Requirements on System Level <ul style="list-style-type: none"> 7.1 Datasheet Compliance 8 Software Requirements on System Level <ul style="list-style-type: none"> 8.1 DTC Monitoring 9 Failure Rates and FMEDA <ul style="list-style-type: none"> 9.1 FMEDA Reference Document 9.2 FMEDA Applicable Standard 9.3 Failure Mode Distribution 9.4 FMEDA Results 10 Provisions Against Dependent Failures <ul style="list-style-type: none"> 10.1 External Parasitic Magnetic Fields 10.2 Environmental constraints 11 Measures to Prevent Systematic Failures <ul style="list-style-type: none"> 11.1 Parasitic Magnetic Fields due to Bus Bar design 11.2 Current Ripple Influences 11.3 CAB-SF 1500-C Fastening 12 Diagnostic <ul style="list-style-type: none"> 12.1 Diagnostic Trouble Codes Monitoring 12.2 Diagnostic Mode / Maintenance Operation 13 Safety-related content of the instructions for operation, service and decommissioning 14 Field Monitoring

*Safety Manual availability after NDA and assurance of business signed.

Applicable standards - PV tests performed - CAB-SF 1500

Test	Standard	Procedure
CHARACTERIZATION AT 25 °C (Initial and final)	LEM CO.60.09.014.0	Sensitivity; Total error; Offset; Linearity error; Current Consumption
CHARACTERIZATION IN TEMPERATURE RANGE (Initial and final)	LEM CO.60.09.014.0	Sensitivity; Total error; Offset; Linearity error; Current Consumption
Environmental test		
Ageing 85 °C /85 % RH	JESD 22-A101 (03/2009)	$T^{\circ}\text{C} = 85^{\circ}\text{C}$; RH = 85 %; Duration = 1000 h Transducer not supply Check After stab. @ 25 °C (End test) Performance after test, from -40 °C to 85 °C: $I_o \leq 50 \text{ mA}$, $\varepsilon_{\text{tot}} \leq 1 \%$
Low temperature storage	ISO 16750-4 § 5.1.1.2 (04/2010)	$T^{\circ}\text{C} = -40^{\circ}\text{C}$ Duration = 24 h; Power off, no monitoring Check After stab. @ 25 °C (End test)
High temperature storage	ISO 16750-4 § 5.1.2.2 (04/2010)	$T^{\circ}\text{C} = 85^{\circ}\text{C}$ Duration = 96 h; Power off, no monitoring Check After stab. @ 25 °C (End test)
Temperature cycle with specified change rate	ISO 16750-4 § 5.3.1 (04/2010)	$T^{\circ}\text{C} = -40^{\circ}\text{C}$ & $+85^{\circ}\text{C}$, see Fig. 2 of ISO 16750-4 Duration = 30 cycles; 1 cycle = 8 h Total duration = 10 days $U_c = 13.5 \text{ V}$ (\equiv connected); $I_p = 0 \text{ A}$; no monitoring Check After stab. @ 25 °C (End test)
Thermal shock	ISO 16750-4 § 5.3.2 (04/2010)	$T^{\circ}\text{C} = "T^{\circ}\text{C Operating min \& max}" -40 \text{ to } +85^{\circ}\text{C}$ Duration = 300 cycles according to the climatic code (defined table 4); Exposure time : 30 min. $U_c = \text{NO power supply}$ (\equiv unconnected) and No wiring harness Check After stab. @ 25 °C (End test)
Random Vibration	ISO 16750-3 § 4.1.2.4 (12/2012)	Random; -40 °C /+85 °C during 8 hours; 8 h for each axie and each DUT; RMS acceleration 27.1 m/s ² Torque measurement before and after. Connected but not supply. No monitoring
Mechanical Shocks	ISO 16750-3 § 4.2 (12/2012)	Temperature: Ambient temperature. Default § 4.2.2 Operating mode: 3.2 Pulse shape: half sine, 50 G, 6 ms 10 shocks per direction (total 60) & Meas. torque Bef. and After Offset before and after; Parts not connected Check After stab. @ 25 °C (End test)
Free Fall	ISO 16750-3 § 4.3 (12/2012)	Number of devices: 3 Falls/DUT: 2 Height = 1 m on Concrete floor 3 axes; 2 directions by axis; 1 sample by axis Operating mode: 1.1 Temperature: 25 °C if not specified Check after test at 25 °C and visual inspection
Cross section checking on PCBA	IPC-A-610G: 2017 Class 3	IPC-TM-650 2.1.1F:2015
Cross section checking on solderless connections	GB/T 18290.5-2015	IPC-TM-650 2.1.1F:2015
Whisker checking on PCBA	Refer to JESD201-A (04/2010)	Refer to JESD22-A121A (04/2010) Class 2

Test	Standard	Procedure
Electrical test		
Reversed voltage	ISO 16750-2 § 4.7 (12/2012)	Test performed at room temperature By default: case 2; Duration : 60 s; Level defined in table 7 according to the nominal system voltage
Overvoltage (for 12 V nominal voltage)	ISO 16750-2 § 4.3.1 (12/2012)	$T^{\circ}\text{C} = T_{\text{max}} - 20^{\circ}\text{C}$ and room temperature; At T_{max} , apply 18 V for 60 min to all inputs; At room temperature, apply 24 V for 60 s
Superimposed alternating voltage	ISO 16750-2 § 4.4 (12/2012)	12 V system severity1: 1 V peak to peak according to Fig. 2 triangular, logarithmic 5 times sweep continuously
Slow decrease and increase of supply voltage	ISO 16750-2 § 4.5 (12/2012)	Test performed at room temperature $U_{\text{S min}} = 8.5\text{ V}$ Decrease from $U_{\text{S min}}$ to 0 V and increase from 0 V to $U_{\text{S min}}$; Change rate: 0.5 V/min > 8.5 V < 8.5 V
Momentary drop in supply voltage	ISO 16750-2 § 4.6.1 (12/2012)	Test performed at room temperature $U_{\text{C min}} = 8.5\text{ V}$ $U_{\text{C min}}$ to 4.5 V See Fig. 4
Reset behavior at voltage drop	ISO 16750-2 § 4.6.2 (12/2012)	Test performed at room temperature See Fig. 6
Load dump	ISO 16750-2 § 4.6.4 (12/2012)	Test performed at room temperature Pulse B, Pulse described in table 6 'System with 12 V nominal voltage Class C $U_{\text{A}} = 14\text{ V}$, $U_{\text{S}}^* = 35\text{ V}$, $U_{\text{S}} = 80\text{ V}$, $R_1 = 1\text{ Ohm}$, $T_d = 400\text{ ms}$, 5 pulses at 1 min intervals See Fig. 9
Ground reference and supply offset	ISO 16750-2 § 4.8 (12/2012)	Test performed at room temperature and test method defined at § 4.8.2
Open circuit test - single line interruption	ISO 16750-2 § 4.9.1 (12/2012)	Operating the transducer and open the circuit line after line. Opening duration for each line: 10 s
Short circuit protection - signals circuits	ISO 16750-2 § 4.10.2 (12/2012)	Connect all inputs and outputs to $U_{\text{S max}} = 16\text{ V}$ and to GND for a duration of 60 s
Withstand voltage	ISO 16750-2 § 4.11 (12/2012)	3.5 KV AC 50 Hz 60 s
Insulation resistance	ISO 16750-2 § 4.12 (12/2012)	1000 V DC for 60 s Resistance criteria: > 1000 MOhm

Test	Standard	Procedure
EMC test		
Resistance to electrostatic discharges (handling device)	ISO 10605 (07/2008)	Contact discharges: ± 8 kV; Air discharges: ± 15 kV. $U_c =$ NO power supply (\equiv unconnected)
Immunity to Radiated field- Anechoic chamber(ALSE with ground plane)	ISO 11452-2 (11/2019)	Test level II and Test level IV <ul style="list-style-type: none"> · CW and AM in the [200 MHz – 800 MHz] frequency band. · CW, AM and PM1 in the [800 MHz – 1 GHz] frequency band. · CW and PM1 in the [1 GHz – 1.2 GHz] frequency band. · CW and PM2 in the [1.2 GHz – 1.4 GHz] frequency band. · CW and PM1 in the [1.4 GHz – 2.7 GHz] frequency band. · CW and PM2 in the [2.7 GHz – 3.2 GHz] frequency band.
Transient Disturbances Conducted along Supply Lines	ISO 7637-2 (03/2011)	test pulse : 1 : -100 V $t_1 = 5$ s (0.2 to 5 s) 2a : 50 V $t_1 = 0.2$ to 5 s 2b : 10 V $t_d = 2$ s 3a : $U - 150$ V 3b : $U 100$ V
Transient Disturbances Conducted along I/O or Transducer Lines	ISO 7637-3 (07/2016)	12 V nominal supply voltage Fast a : CCC -150 V 10 min Fast b : CCC $+100$ V 10 min slow pulse positive: ICC $+20$ V 20 min slow pulse negative: ICC -20 V 20 min
Immunity to Bulk Current Injection (BCI)	ISO 11452-4 (12/2011)	Table E.1 Test level I, 1 MHz to 3 MHz : 60 mA * F(MHz) /3 3 to 400 MHz : 60 mA Test level II, 1 MHz to 3 MHz : 100 mA * F(MHz) /3 3 to 400 MHz : 100 mA Test level IV, 1 MHz to 3 MHz : 200 mA * F(MHz) /3 3 to 400 MHz : 200 mA
Conducted emission - Voltage method	CISPR 25 (2016) § 6.3	Table 5, Class 3, BROADCAST and MOBILE SERVICES $f = 0.15$ MHz to 108 MHz
Radiated emission - ALSE	CISPR 25 (2016) § 6.5	Table 7, Class 3, BROADCAST and MOBILE SERVICES
Immunity to magnetic fields	ISO 11452-8 (2015)	12 V Nominal supply voltage radiating loop method Test requirement see TableA.1(Internal filed) Test level I FPSC Status I