

For the electronic measurement of voltage: DC, AC, pulsed..., with galvanic separation between the primary and the secondary circuit.

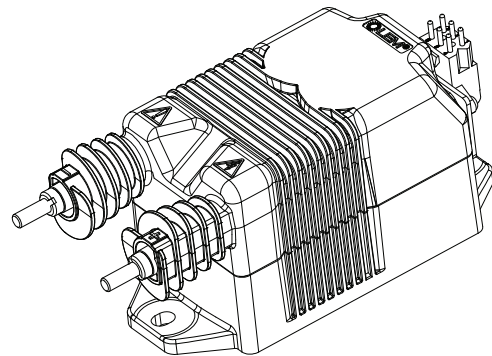

## Features

- Unipolar and insulated measurement up to 6000 V
- Unipolar supply voltage
- Voltage output
- Input connections with M5 studs
- Voltage threshold output
- SMS6GE6 Burndy connector is used for secondary connection.

## Special feature

- Customer marking: DTR 0000440784.

## Advantages

- Low consumption and low losses
- Compact design
- Very low sensitivity to common mode voltage variations
- Excellent accuracy (offset, sensitivity, linearity)
- Low temperature drift
- High immunity to external interferences.

## Applications

- Single or three phase inverters
- Propulsion and braking choppers
- Propulsion converters
- Auxiliary converters
- High power drives
- Substations.

## Standards

- EN 50155: 2007
  - EN 50121-3-2: 2015
  - EN 50124-1: 2001
  - IEC 61010-1: 2010
  - IEC 61800-1: 1997
  - IEC 61800-2: 2015
  - IEC 61800-3: 2004
  - IEC 61800-5-1: 2007
  - IEC 62109-1: 2010
  - UL 347 <sup>1)</sup>: 2016
- <sup>1)</sup> When used with UL 347 Isolator N° 92.24.06.420.0.

## Application Domain

- Traction (trackside and onboard)
- Industrial.

## Absolute maximum ratings

Parameter	Symbol	Value
Maximum supply voltage ( $V_p = 0 \text{ V}$ , 0.1 s)	$U_{C \text{ max}}$	34.6
Maximum supply voltage (working) (-40 ... 85 °C)	$U_{C \text{ max}}$	30
Maximum primary voltage (-40 ... 85 °C)	$V_{P \text{ max}}$	6000
Maximum steady state primary voltage (-40 ... 85 °C)	$V_{P \text{ N max}}$	4000

Absolute maximum ratings apply at 25 °C unless otherwise noted.  
 Stresses above these ratings may cause permanent damage.  
 Exposure to absolute maximum ratings for extended periods may degrade reliability.

## UL 347: Ratings and assumptions of certification

File # E315896 Volume: 1 Section: 3

### Standards

- CSA C22.2 No. 253 Medium-Voltage AC Contactors, Controllers, and Control Centers
- UL 347 Standards for Safety for Medium-Voltage AC Contactors, Controllers, and Control Centers.

### Conditions of acceptability

When installed in the end-use equipment, consideration shall be given to the following:

- 1 - These devices must be mounted in a suitable end-use enclosure.
- 2 - The terminals have not been evaluated for field wiring.
- 3 - The rated Basic Insulation Level (BIL) is 20 kV for this device, after performing Impulse Withstand Tests. Additional testing will be required if a higher BIL rating is desired.
- 4 - For products rated more than 2500 V, the specific kit model "UL 347 isolator" shall be mounted to the DVM.
- 5 - The products have been evaluated for a maximum surrounding air temperature of 85 °C..
- 6 - Low voltage circuits are intended to be powered by a circuit derived from an isolating source (such as a transformer, optical isolator, limiting impedance or electro-mechanical relay) and having no direct connection back to the primary circuit (other than through the grounding means).

### Marking

Only those products bearing the UL or UR Mark should be considered to be Listed or Recognized and covered under UL's Follow-Up Service. Always look for the Mark on the product.

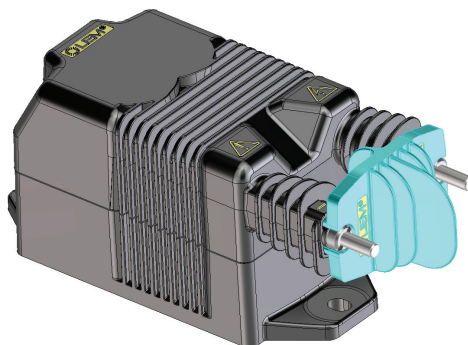

Assembly of UL 347 Isolator on primary studs.  
 UL 347 Isolator, reference number 92.24.06.420.0, to be ordered separately.

**Insulation coordination**

Parameter	Symbol	Unit	Value	Comment
RMS voltage for AC insulation test, 50 Hz, 1 min	$U_d$	kV	12	100 % tested in production
Impulse withstand voltage 1.2/50 $\mu$ s	$\hat{U}_W$	kV	30	
Partial discharge extinction RMS voltage @ 10 pC	$U_e$	V	5000	
Insulation resistance	$R_{INS}$	M $\Omega$	200	
Clearance (pri. - sec.)	$d_{CI}$	mm	See dimensions drawing on page 10	Shortest distance through air
Creepage distance (pri. - sec.)	$d_{CP}$	mm		Shortest path along device body
Case material	-	-	V0	According to UL 94
Comparative tracking index	$CTI$	V	600	
Maximum DC common mode voltage	$V_{HV+} + V_{HV-}$ and $ V_{HV+} - V_{HV-} $	kV	$\leq 6.3$ $\leq V_{PM}$	

**Environmental and mechanical characteristics**

Parameter	Symbol	Unit	Min	Typ	Max
Ambient operating temperature	$T_A$	$^{\circ}$ C	-40		70
Ambient storage temperature	$T_S$	$^{\circ}$ C	-50		90
Mass	$m$	g		375	

**Electrical threshold detection data**

At  $T_A = 25\text{ }^\circ\text{C}$ ,  $+U_C = +24\text{ V}$ ,  $R_M = 2\text{ k}\Omega$ , unless otherwise noted.

Lines with a \* in the conditions column apply over the  $-40 \dots 70\text{ }^\circ\text{C}$  ambient temperature range.

Parameter	Symbol	Unit	Min	Typ	Max	Conditions
Primary high threshold voltage	$U_{PHTh}$	V		500		$\pm 10\%$
Primary low threshold voltage	$U_{PLTh}$	V		400		$\pm 10\%$
Maximum secondary (output) voltage when threshold detection is active	$U_{S Th max}$	V			30	
Maximum secondary (output) current when threshold detection is active	$I_{S Th max}$	mA			100	No overcurrent protection
Minimum load resistance, threshold detection output	$R_{L Th min}$	$\Omega$	300			
Response time of threshold output for high value	$t_{r H Th}$	ms		2		0 to $V_{PN}$ transition
Response time of threshold output for low value	$t_{r L Th}$	ms		700		$V_{PN}$ to 0 transition

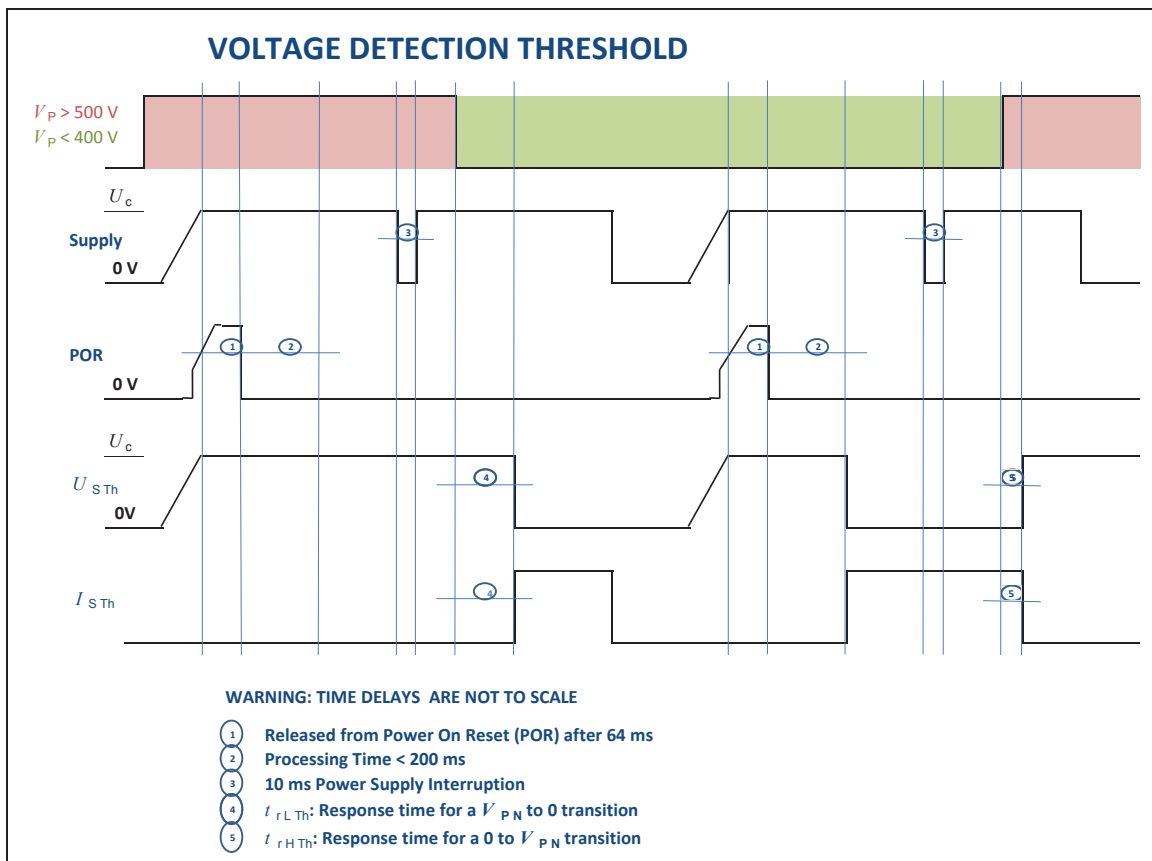

Figure 1: Voltage detection threshold timing diagram

**Electrical data**

At  $T_A = 25\text{ °C}$ ,  $+U_C = +24\text{ V}$ ,  $R_M = 2\text{ k}\Omega$ , unless otherwise noted.

Lines with a \* in the conditions column apply over the  $-40 \dots 70\text{ °C}$  ambient temperature range.

Parameter	Symbol	Unit	Min	Typ	Max	Conditions
Primary nominal RMS voltage	$V_{PN}$	V			4000	*
Primary voltage, measuring range	$V_{PM}$	V	-6000		6000	*
Measuring resistance	$R_M$	$\Omega$	2000			*
Secondary nominal RMS voltage	$V_{SN}$	V		6.66		*
Secondary voltage	$V_S$	V	-10		10	*
Supply voltage	$U_C$	V	16.8		30	*
Rise time of $U_C$ (10-90 %)	$t_{rise}$	ms			100	
Current consumption @ $U_C = +24\text{ V}$ at $V_P = 0\text{ V}$ and $I_{S_{Th}} = 0$	$I_C$	mA		50		
Offset voltage	$V_O$	mV	-7		7	100 % tested in production
Temperature variation of $V_O$	$V_{OT}$	mV	-25 -30		25 30	* -25 ... 70 °C -40 ... 70 °C
Sensitivity	$G$	mV/V		1.66		10 V for primary 6000 V
Sensitivity error	$\epsilon_G$	%	-0.3		0.3	
Thermal drift of sensitivity	$\epsilon_{GT}$	%	-0.5		0.5	*
Linearity error	$\epsilon_L$	% of $V_{PM}$	-0.5		0.5	$\pm 6000\text{ V}$ range
Overall accuracy	$X_G$	% of $V_{PN}$	-0.5 -1		0.5 1	* 25 °C; 100 % tested in production; -40 ... 70 °C
Output RMS noise voltage	$V_{no}$	mV		2.4		10 Hz to 100 kHz
Reaction time @ 10 % of $V_{PN}$	$t_{ra}$	$\mu\text{s}$		30		
Response time @ 90 % of $V_{PN}$	$t_r$	$\mu\text{s}$		50	60	0 to 4000 V step, 6 kV/ $\mu\text{s}$
Frequency bandwidth	$BW$	kHz		14 8		-3 dB -1 dB
Start-up time	$t_{start}$	ms		190	250	*
Resistance of primary (winding)	$R_P$	M $\Omega$		25.1		*
Total primary power loss @ $V_{PN}$	$P_P$	W		0.64		*

**Definition of typical, minimum and maximum values**

Minimum and maximum values for specified limiting and safety conditions have to be understood as such as well as values shown in "typical" graphs. On the other hand, measured values are part of a statistical distribution that can be specified by an interval with upper and lower limits and a probability for measured values to lie within this interval. Unless otherwise stated (e.g. "100 % tested"), the LEM definition for such intervals designated with "min" and "max" is that the probability for values of samples to lie in this interval is 99.73 %. For a normal (Gaussian) distribution, this corresponds to an interval between  $-3\text{ sigma}$  and  $+3\text{ sigma}$ . If "typical" values are not obviously mean or average values, those values are defined to delimit intervals with a probability of 68.27 %, corresponding to an interval between  $-\text{sigma}$  and  $+\text{sigma}$  for a normal distribution. Typical, maximal and minimal values are determined during the initial characterization of a product.

Typical performance characteristics

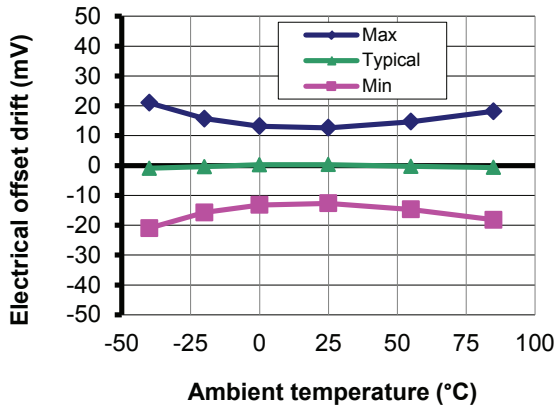

Figure 2: Electrical offset thermal drift

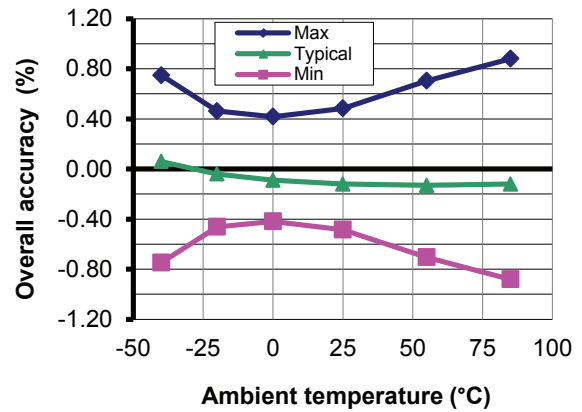

Figure 3: Overall accuracy in temperature

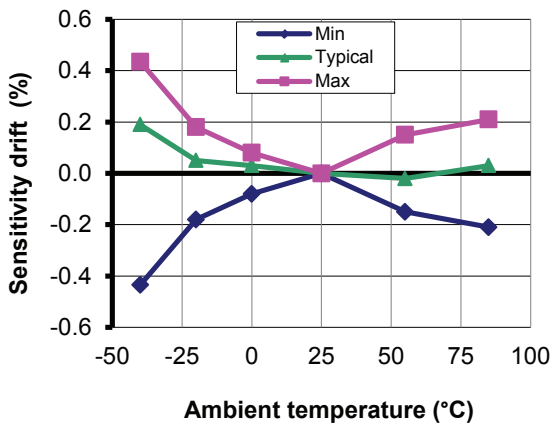

Figure 4: Sensitivity thermal drift

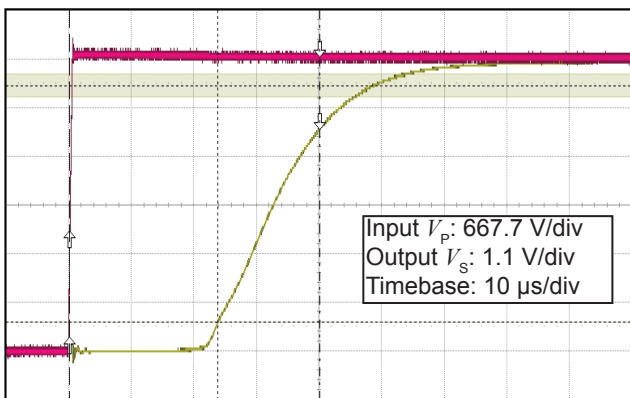

Figure 5: Typical step response (0 to 4000 V)

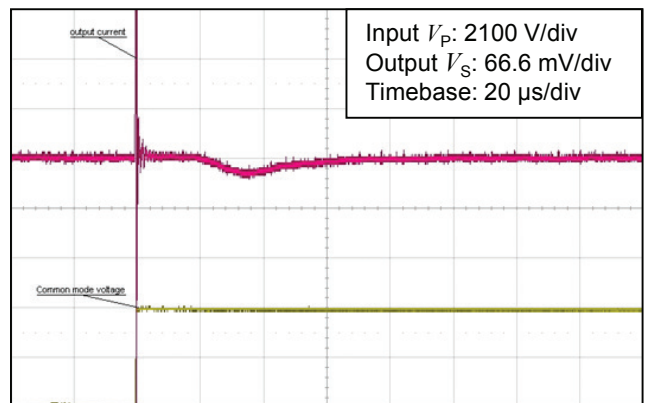

Figure 6: Detail of typical common mode perturbation (4200 V step with 6 kV/μs,  $R_M = 2 \text{ k}\Omega$ )

Typical performance characteristics continued

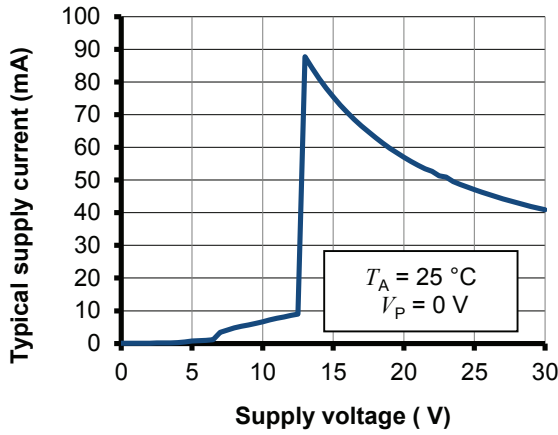

Figure 7: Supply current function of supply voltage

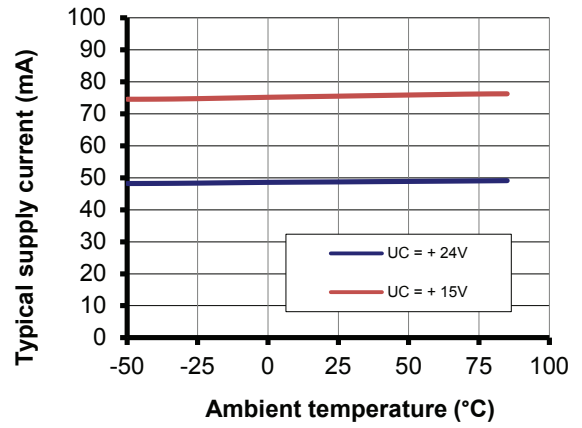

Figure 8: Supply current function of temperature

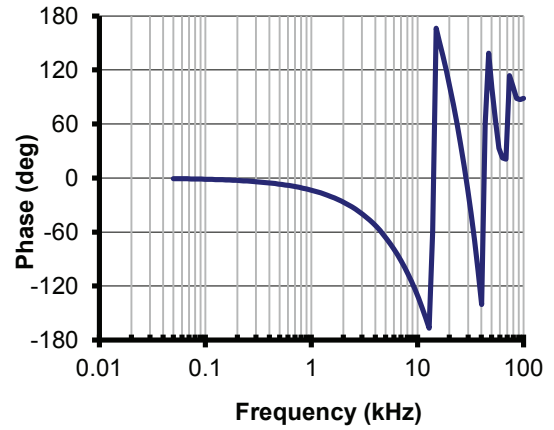
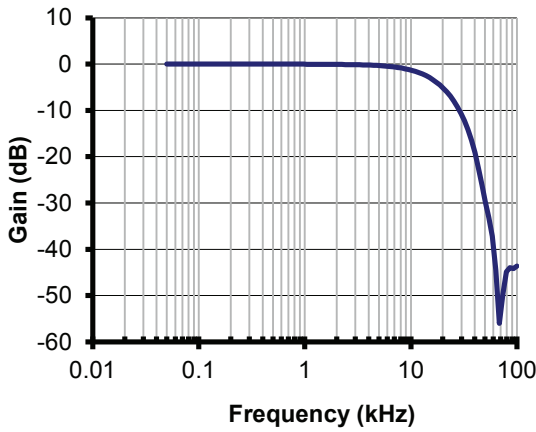

Figure 9: Typical frequency and phase response

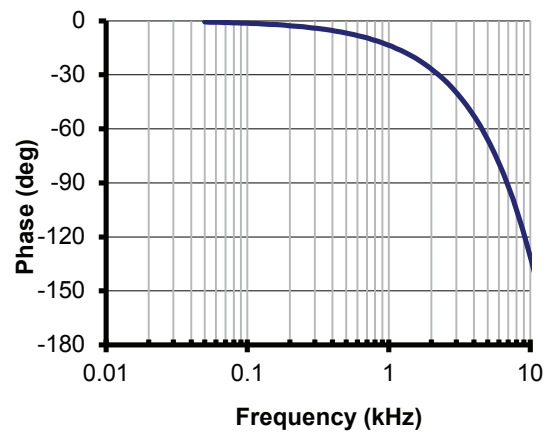
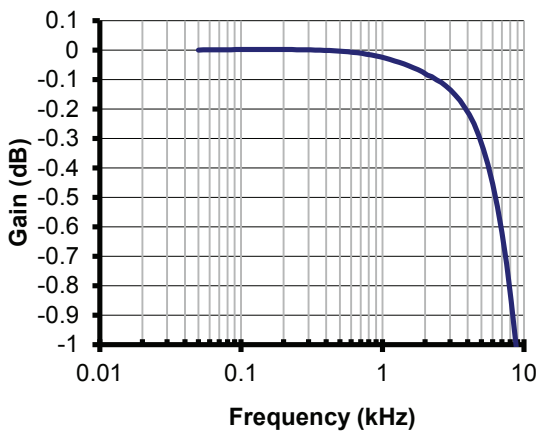

Figure 10: Typical frequency and phase response (detail)

Typical performance characteristics

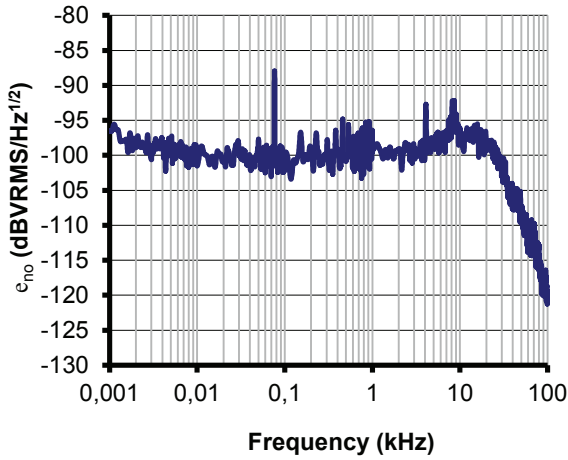

Figure 11: Typical total output RMS noise voltage spectral density  $e_{no}$  with  $R_M = 2\text{ k}\Omega$

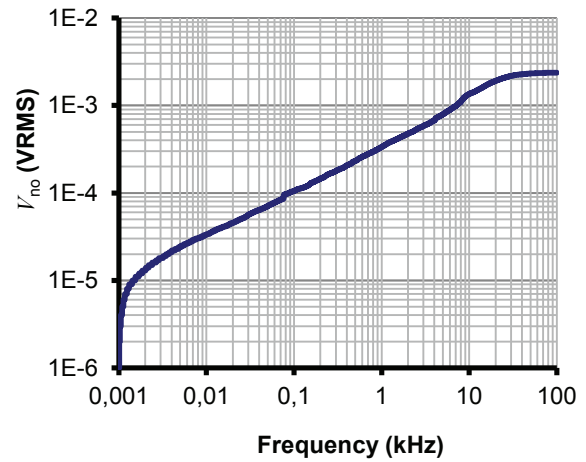

Figure 12: Typical total output RMS noise voltage spectral density  $V_{no}$  with  $R_M = 2\text{ k}\Omega$

Figure 11 (noise voltage spectral density) shows that there are no significant discrete frequencies in the output. Figure 12 confirms the absence of steps in the total output voltage noise that would indicate discrete frequencies. To calculate the noise in a frequency band  $f1$  to  $f2$ , the formula is:

$$V_{no}(f1\text{ to }f2) = \sqrt{V_{no}(f2)^2 - V_{no}(f1)^2}$$

with  $V_{no}(f)$  read from figure 12 (typical, RMS value).

Example:

What is the noise from 10 to 1 kHz?

Figure 12 gives  $V_{no}(10\text{ Hz}) = 33\text{ }\mu\text{V}$  and  $V_{no}(1\text{ kHz}) = 336\text{ }\mu\text{V}$ . The output RMS voltage noise is therefore.

$$\sqrt{(336 \times 10^{-6})^2 - (33 \times 10^{-6})^2} = 334\text{ }\mu\text{V}$$



### Performance parameters definition

The schematic used to measure all electrical parameters are:

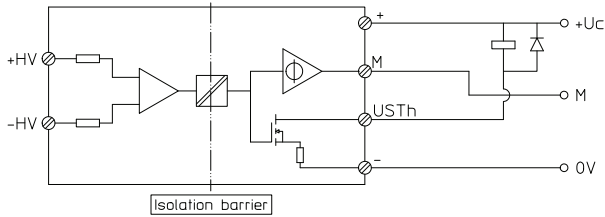

Figure 13: Standard characterization schematics for voltage output transducers ( $R_M = 2\text{ k}\Omega$  unless otherwise noted)

### Transducer simplified model

The static model of the transducer at temperature  $T_A$  is:

$$V_S = G \cdot V_P + \varepsilon$$

In which

$$\varepsilon = I_{OE} + I_{OT}(T_A) + \varepsilon_G \cdot G \cdot V_P + \varepsilon_{GT}(T_A) \cdot G \cdot V_P + \varepsilon_L \cdot G \cdot V_{PM}$$

- $V_S$  : secondary voltage (V)
- $G$  : sensitivity of the transducer (V/V)
- $V_P$  : primary voltage (V)
- $V_{PM}$  : primary voltage, measuring range (V)
- $T_A$  : ambient operating temperature ( $^{\circ}\text{C}$ )
- $V_{OE}$  : electrical offset voltage (V)
- $V_{OT}(T_A)$  : temperature variation of  $V_O$  at temperature  $T_A$  (V)
- $\varepsilon_G$  : sensitivity error at  $25\text{ }^{\circ}\text{C}$
- $\varepsilon_{GT}(T_A)$  : thermal drift of sensitivity at temperature  $T_A$
- $\varepsilon_L$  : linearity error

This is the absolute maximum error. As all errors are independent, a more realistic way to calculate the error would be to use the following formula:

$$\varepsilon = \sqrt{\sum_{i=1}^N \varepsilon_i^2}$$

### Sensitivity and linearity

To measure sensitivity and linearity, the primary voltage (DC) is cycled from 0 to  $V_{PM}$ , then back to 0 (equally spaced  $V_{PM}/10$  steps).

The sensitivity  $G$  is defined as the slope of the linear regression line for a cycle between  $V_{PM}$ . The linearity error  $\varepsilon_L$  is the maximum positive or negative difference between the measured points and the linear regression line, expressed in % of the maximum measured value.

### Electrical offset

The electrical offset voltage  $V_{OE}$  is the residual output voltage when the input voltage is zero.

The temperature variation  $V_{OT}$  of the electrical offset voltage  $V_{OE}$  is the variation of the electrical offset from  $25\text{ }^{\circ}\text{C}$  to the considered temperature.

### Overall accuracy

The overall accuracy  $X_G$  is the error at  $V_{PN}$ , relative to the rated value  $V_{PN}$ . It includes all errors mentioned above.

### Response and reaction times

The response time  $t_r$  and the reaction time  $t_{ra}$  are shown in the next figure.

Both depend on the primary voltage  $dv/dt$ . They are measured at nominal voltage.

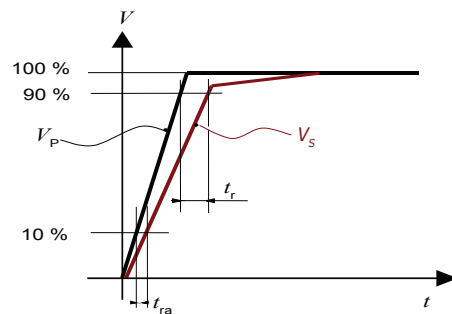
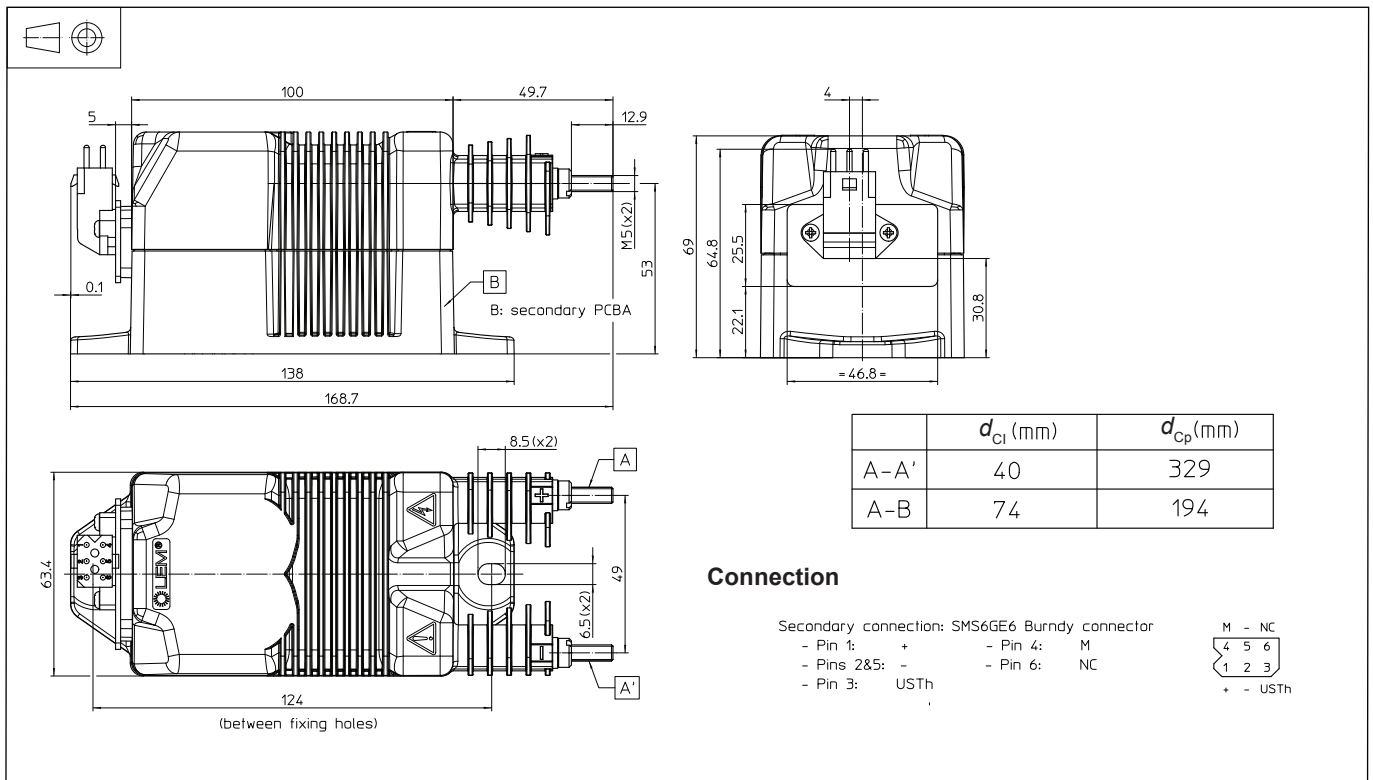

Figure 14: response time  $t_r$  and reaction time  $t_{ra}$

**Dimensions** (in mm)

**Mechanical characteristics**

- General tolerance  $\pm 1$  mm
- Transducer fastening
  - 2 holes  $\varnothing$  6.5 mm
  - 2 M6 steel screws
  - Recommended fastening torque 5 N·m
- Connection of primary
  - 2 M5 threaded studs
  - Recommended fastening torque 2.2 N·m
- Connection of secondary SMS6GE6 Burndy

**Remarks**

- $I_s$  is positive when a positive voltage is applied on +HV.
- The transducer is directly connected to the primary voltage.
- The primary cables have to be routed together all the way.
- The secondary cables also have to be routed together all the way.
- Installation of the transducer is to be done without primary or secondary voltage present
- Installation of the transducer must be done unless otherwise specified on the datasheet, according to LEM Transducer Generic Mounting Rules. Please refer to LEM document N°ANE120504 available on our Web site: [Products/Product Documentation](#).
- This is a standard model. For different versions (supply voltages, sensitivity, unidirectional measurements...), please contact us.

**Safety**

This transducer must be used in limited-energy secondary circuits according to IEC 61010-1.



This transducer must be used in electric/electronic equipment with respect to applicable standards and safety requirements in accordance with the manufacturer's operating instructions.



Caution, risk of electrical shock

When operating the transducer, certain parts of the module can carry hazardous voltage (e.g. primary connections, power supply). Ignoring this warning can lead to injury and/or cause serious damage. This transducer is a build-in device, whose conducting parts must be inaccessible after installation. A protective housing or additional shield could be used. Main supply must be able to be disconnected.