

AUTOMOTIVE CURRENT TRANSDUCER OPEN LOOP TECHNOLOGY

HC5FW 300-S/SP1

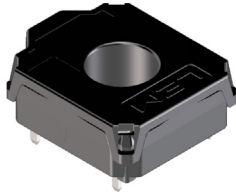

Introduction

The HC5FW family is for the electronic measurement of DC, AC or pulsed currents in high power and low voltage automotive applications with galvanic separation between the primary circuit (high power) and the secondary circuit (electronic circuit).

The HC5FW family gives you the choice of having different current measuring ranges in the same housing.

Features

- Open Loop transducer using the Hall effect
- Low voltage application
- Unipolar +5 V DC power supply
- Primary current measuring range up to ± 300 A
- Maximum RMS primary current limited by the busbar, the magnetic core or the ASIC temperature $T < +150$ °C
- Operating temperature range: -40 °C $< T < +125$ °C
- Output voltage: full ratiometric (sensitivity and offset)
- High speed transducer.

Special feature

- Cover without sleeve (reduced insulation).

Advantages

- Good accuracy
- Good linearity
- Low thermal offset drift
- Low thermal sensitivity drift.

Automotive applications

- Electrical Power Steering
- Starter Generators
- Converters.

Principle of HC5FW Family

The open loop transducers uses a Hall effect integrated circuit. The magnetic flux density B , contributing to the rise of the Hall voltage, is generated by the primary current I_p to be measured. The current to be measured I_p is supplied by a current source i.e. battery or generator (Figure 1).

Within the linear region of the hysteresis cycle, B is proportional to:

$$B(I_p) = a \times I_p$$

The Hall voltage is thus expressed by:

$$U_{Hall} = (c_{Hall} / d) \times I_{Hall} \times a \times I_p$$

Except for I_p , all terms of this equation are constant. Therefore:

$$U_{Hall} = b \times I_p$$

a constant

b constant

c_{Hall} Hall coefficient

d thickness of the Hall plate

I_{Hall} current across Hall plates

The measurement signal U_{Hall} is amplified to supply the user output voltage or current.

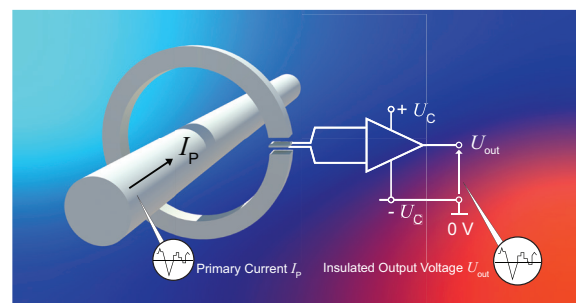
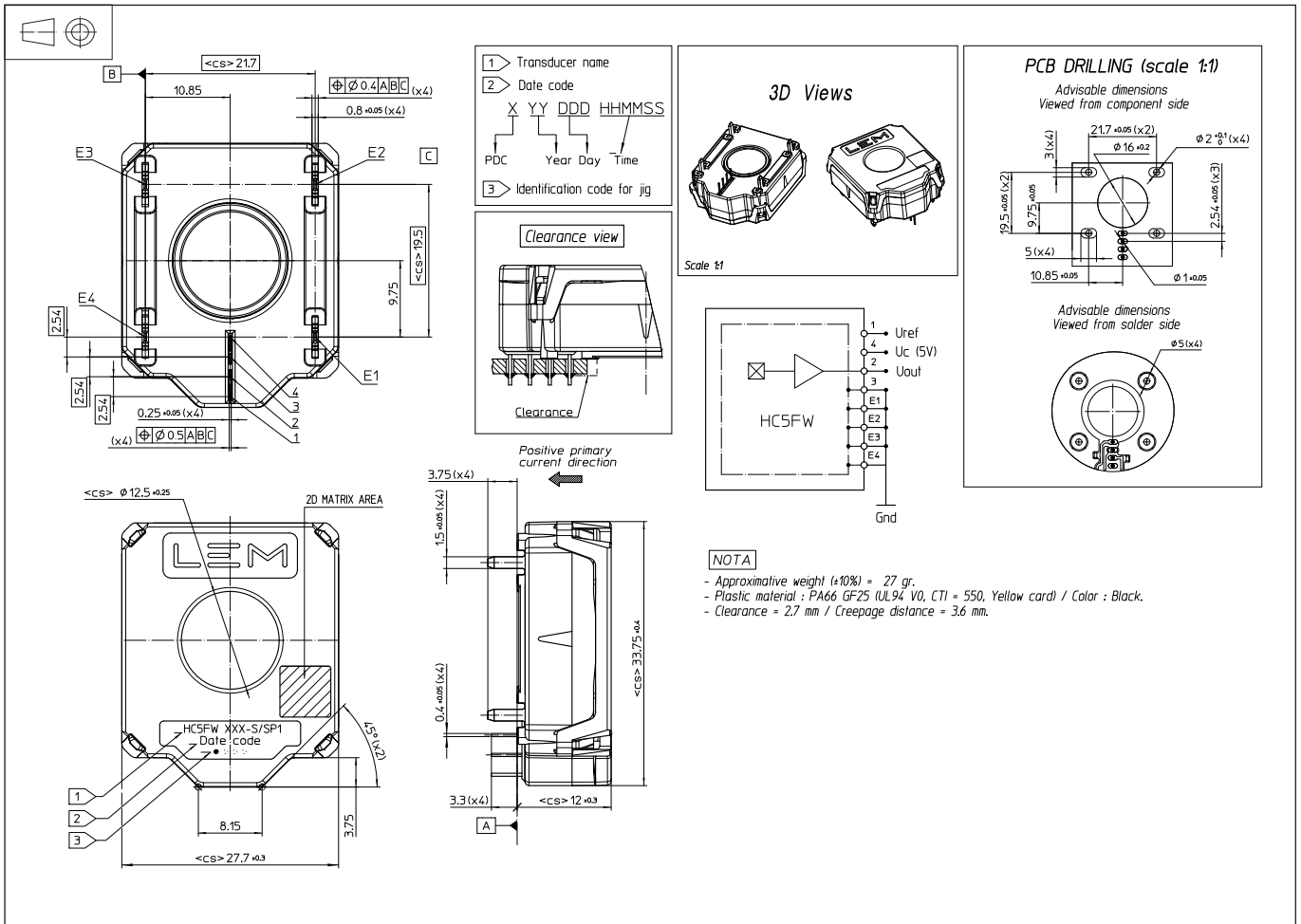

Fig. 1: Principle of the open loop transducer.



Mechanical characteristics

- Plastic case PA 66 GF 25
- Magnetic core FeSi alloy
- Mass 27 g
- Electrical terminal coating Tin plated
- IP level IPx00
- General tolerance ±0.25 mm

Mounting recommendation

- Connector type None
- Assembly torque max None
- Soldering profile See page 7

Electronic schematic

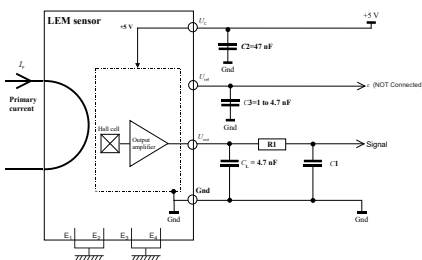

Remarks

- $I_p = \left(\frac{5}{U_c} \times U_{out} - U_o \right) \times \frac{1}{S}$ with S in (V/A)
- $U_{out} > U_o$ when I_p flows in the positive direction (see arrow on drawing)
- R1, C1: low pass filter (optional).

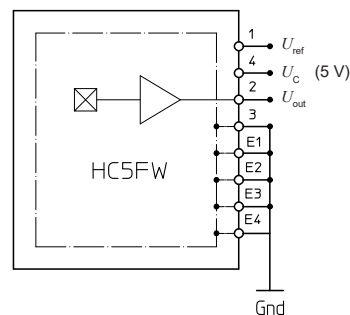

Absolute ratings (not operating)

HC5FW 300-S/SP1

Parameter	Symbol	Unit	Specification			Conditions
			Min	Typical	Max	
Maximum supply voltage	$U_{C\max}$	V			8	not operating
					6.5	Exceeding this voltage may temporary reconfigure the circuit until the next power-on
Maximum primary current peak	$\hat{I}_{P\max}$	A			3)	
Ambient storage temperature	$T_{A\text{st}}$	°C	-40		125	
Electrostatic discharge voltage	$U_{\text{ESD HBM}}$	kV			2	JESD22-A114-B class 2
Maximum admissible vibration (random)	γ_{\max}	m·s ⁻²	90			10 to 1000 Hz
RMS voltage for AC insulation test, 50 Hz, 1 min	U_d	kV			2.5	50 Hz, 1 min, IEC 60664 part1
Insulation resistance	R_{INS}	MΩ	500			
Creepage distance	d_{Cp}	mm	3.6			
Clearance	d_{Cl}	mm	2.7			
Comparative tracking index	CTI		550			
Maximum reverse current	$I_{\text{rev max}}$	mA	-80		80	

Operating characteristics in nominal range (I_{PN})

Parameter	Symbol	Unit	Specification			Conditions
			Min	Typical	Max	
Electrical Data						
Primary current, measuring range	I_{PM}	A	-300		300	
Primary nominal DC or RMS current	I_{PN}	A	-300		300	
Supply voltage ¹⁾	U_C	V	4.75	5.00	5.25	
Ambient operating temperature	T_A	°C	-40		125	
Output voltage (Analog)	U_{out}	V	$U_{\text{out}} = (U_C/5) \times (U_O + S \times I_p)$			@ U_C
Sensitivity	S	mV/A		6.667		@ $U_C = 5\text{ V}$
Offset voltage	U_O	V		2.5		@ $U_C = 5\text{ V}$
Current consumption	I_C	mA		19	25	@ $U_C = 5\text{ V}$, -40 °C < T_A < 125 °C
Load resistance	R_L	KΩ	10			
Load capacitance	C_L	nF		4.7	6.8	
Output internal resistance	R_{out}	Ω			10	DC to 1 KHz
Performance Data ¹⁾						
Ratiometricity error	ϵ_r	%		0.5		
Sensitivity error	ϵ_S	%		±0.6		@ $T_A = 25\text{ °C}$
Electrical offset voltage	U_{OE}	mV		±3.5		@ $T_A = 25\text{ °C}$, @ $U_C = 5\text{ V}$
Magnetic offset voltage	U_{OM}	mV		±2		@ $T_A = 25\text{ °C}$, @ $U_C = 5\text{ V}$, after $\pm I_p$
Total error @ 0 A	ϵ_{tot}	mV	-13		13	@ $T_A = 25\text{ °C}$, @ $U_C = 5\text{ V}$, Hysteresis included
Average temperature coefficient of U_{OE}	TCU_{OEAV}	mV/°C	-0.08		0.08	@ -40 °C < T < 125 °C
Average temperature coefficient of S	TCS_{AV}	%/°C	-0.03		0.03	@ -40 °C < T < 125 °C
Linearity error	ϵ_L	% I_p	-1		1	Of full range
Delay time to 90 % to the final output value for I_{PN} step	t_{D90}	μs		2	6	$di/dr = 100\text{ A}/\mu\text{s}$
Frequency bandwidth ²⁾	BW	kHz	40			@ -3 dB
Phase shift	$\Delta\varphi$	°C	-4		0	@ DC to 1 kHz
Minimum output voltage	$U_{\text{out min}}$	V			0.2	@ $U_C = 5\text{ V}$
Maximum output voltage	$U_{\text{out max}}$	V	4.8			@ $U_C = 5\text{ V}$
Output voltage noise peak-peak	$U_{\text{no pp}}$	mV			15	DC to 1 MHz

Notes: ¹⁾ The output voltage U_{out} is fully ratiometric. The offset and sensitivity are dependent on the supply voltage U_C relative to the following formula:

$$I_p = \left(\frac{5}{U_C} \times U_{\text{out}} - U_O \right) \times \frac{1}{S} \text{ with } S \text{ in (V/A)}$$

²⁾ Small signal only to avoid excessive heating of the busbar, core and heating. Measurement with $C3 = 1\text{ nF}$.

³⁾ Busbar temperature must be below 150 °C.

Absolute Error (mV)

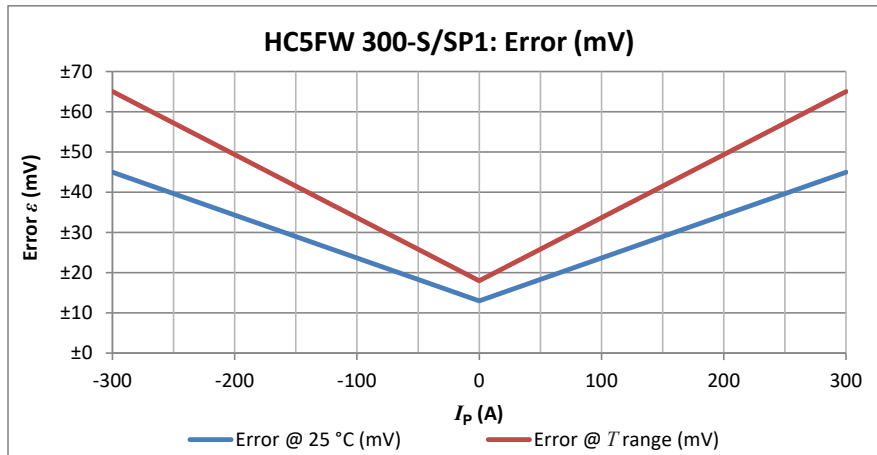

I_p (A)	Error @ 25 °C (mV)	Error @ T Range (mV)
-300	±45	±65
0	±13	±18
300	±45	±65

Accuracy error specified at ± 3 sigma.

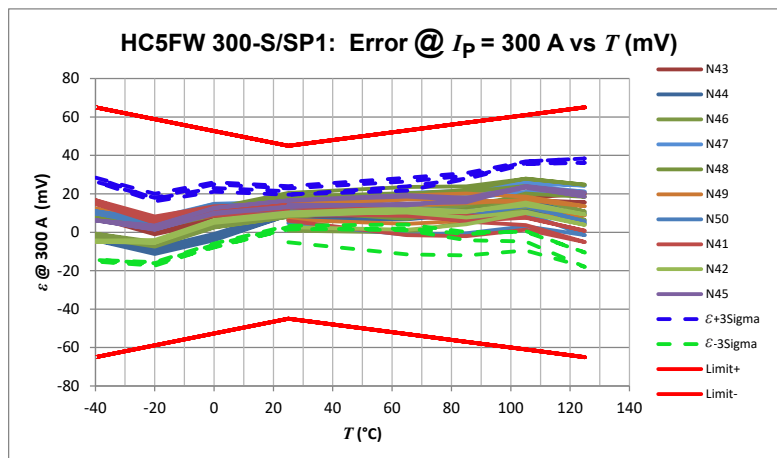
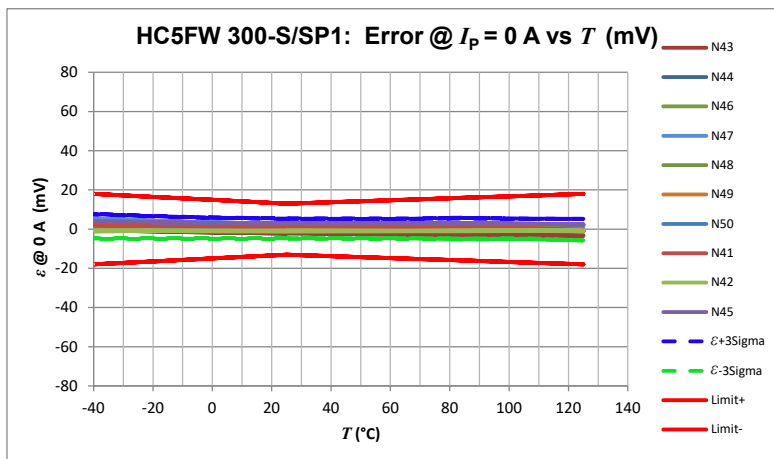

Notes: Curves in red line represent the tolerance
Curves in dotted line represent average ± 3 sigma.

PERFORMANCES PARAMETERS DEFINITIONS

Primary current definition:

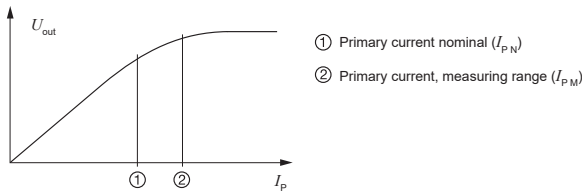

Definition of typical, minimum and maximum values:

Minimum and maximum values for specified limiting and safety conditions have to be understood as such as values shown in "typical" graphs. On the other hand, measured values are part of a statistical distribution that can be specified by an interval with upper and lower limits and a probability for measured values to lie within this interval. Unless otherwise stated (e.g. "100 % tested"), the LEM definition for such intervals designated with "min" and "max" is that the probability for values of samples to lie in this interval is 99.73 %. For a normal (Gaussian) distribution, this corresponds to an interval between -3 sigma and +3 sigma. If "typical" values are not obviously mean or average values, those values are defined to delimit intervals with a probability of 68.27 %, corresponding to an interval between -sigma and +sigma for a normal distribution. Typical, minimum and maximum values are determined during the initial characterization of a product.

Output noise voltage:

The output voltage noise is the result of the noise floor of the Hall elements and the linear amplifier.

Magnetic offset:

The magnetic offset is the consequence of an any current on the primary side. It's defined after a stated excursion of primary current.

Linearity:

The maximum positive or negative discrepancy with a reference straight line $U_{out} = f(I_p)$.
 Unit: linearity (%) expressed with full scale of $I_{p,N}$.

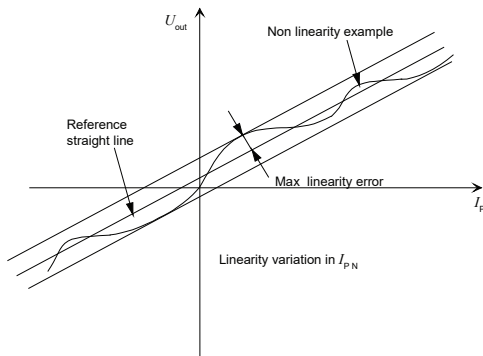

Delay time t_{D90} :

The time between the primary current signal ($I_{p,N}$) and the output signal reach at 90 % of its final value.

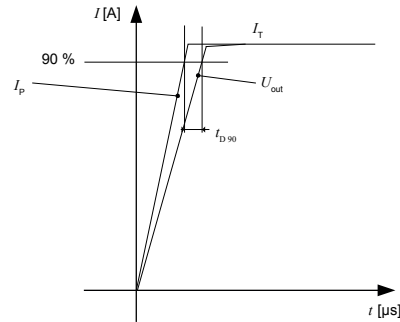

Sensitivity:

The transducer's sensitivity S is the slope of the straight line

$U_{out} = f(I_p)$, it must establish the relation:

$$U_{out}(I_p) = U_c/5 (S \times I_p + U_o)$$

Offset with temperature:

The error of the offset in the operating temperature is the variation of the offset in the temperature considered with the initial offset at 25 °C.

The offset variation $I_{O,T}$ is a maximum variation the offset in the temperature range:

$$I_{O,T} = I_{O,E} \max - I_{O,E} \min$$

The offset drift $TCI_{O,E,AV}$ is the $I_{O,T}$ value divided by the temperature range.

Sensitivity with temperature:

The error of the sensitivity in the operating temperature is the relative variation of sensitivity with the temperature considered with the initial offset at 25 °C.

The average temperature coefficient of sensitivity TCS_{AV} , S_T is the maximum temperature variation of S (in ppm or %) of the sensitivity in the temperature range:

$$S_T = (\text{Sensitivity max} - \text{Sensitivity min}) / \text{Sensitivity at } 25^\circ\text{C}$$

The average temperature coefficient of sensitivity TCS_{AV} is the S_T value divided by the temperature range.

Deeper and detailed info available is our LEM technical sales offices (www.lem.com).

Offset voltage @ $I_p = 0$ A:

The offset voltage is the output voltage when the primary current is zero. The ideal value of U_o is $U_c/2$. So, the difference of $U_o - U_c/2$ is called the total offset voltage error. This offset error can be attributed to the electrical offset (due to the resolution of the ASIC quiescent voltage trimming), the magnetic offset, the thermal drift and the thermal hysteresis. Deeper and detailed info available is our LEM technical sales offices (www.lem.com).

Environmental test specifications:

Refer to LEM GROUP test plan laboratory CO.11.11.515.0 with "Tracking_Test Plan_Auto" sheet.

Environmental test specifications:

Refer to LEM GROUP test plan laboratory CO.11.11.515.0 with "Tracking_Test Plan_Auto" sheet.

Name	Standard
THERMAL FATIGUE	
Ageing 85 °C / 85 % HR / 1000 h Thermal cycle test -40 °C / 125 °C / 1000 h Thermal shocks -40 °C / 125 °C / 1000 h High temperature storage at 125 °C / 1000 h Low temperature storage at -50 °C / 1000 h	IEC 60068-2-78 (2001) IEC 60068-2-14 test Nb (01.2009) IEC 60068-2-14 test Na (01.2009) IEC 60068-2-2 (07.2007) IEC 60068-2-1 (03.2007)
MECHANICAL FATIGUE	
Shocks test (50 m·s ⁻² x 10 x 3 axis) Vibration test (random 10 - 2000 Hz / 9.723 g)	IEC 60068-2-27 test Ea (2008)
ELECTRICAL TESTS	
Phase delay Output noise di/dt (100 A/μs) du/dt (2 kVA/μs to 2 kV) Withstand voltage (2500 V RMS - 50 Hz / 1 min) Insulation resistance (500 V dc / 1 min)	-- 98.20.00.575.0 98.20.00.545.0 98.20.00.545.0 ISO 16750-2 (2012)
EMC TESTS	
Radiated Emissions: Absorber Lined Shielded Enclosure (ALSE) Radiated Immunity: Bulk Current Injection (BCI) Radiated Immunity: Anechoic chamber Resistance to Electrostatic Discharge Voltage	IEC CISPR25 ISO 11452-1 & -4 ISO 11452-1 & -2 ISO 10605 (2001)

PCB recommendations:

1 - Iron Soldering plated-through holes device

- Mass pin (E1 to E4 see on drawing page 2): 200 W / 370 °C Iron temperature / 7 mm flat W200 Weller
- ASIC terminals (1,2,3,4 see on drawing page 2): 80 W / 410 °C Iron temperature / 0.8 mm diameter STTC125 - Metcal

2 - Wave soldering plated-through holes device

LEM recommends to use the following equipment/parameters for the soldering of the HC5FW family in order to be compliant with the IPC A-610 (less than 75 % land coverage):

- Machine VITRONICS SOLTEC 6622 in combi wave mode
- Flux SLS 65
- Sn96 lead free solder (SAC 305)
- Temperature profile as below
- PCB 2143-00 - thickness: 1.6 mm - mass pin E1 to E4: hole Ø 2 - Asic pin: hole Ø 1.

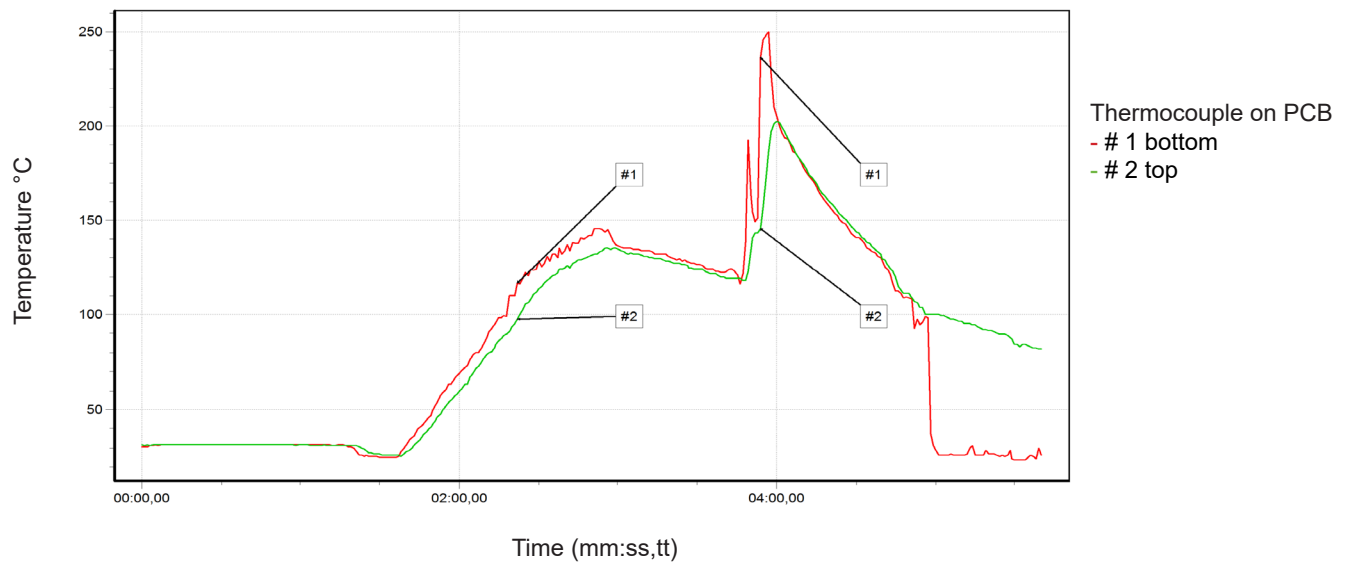

3 - SMD soldering by pin in paste STH (SMD through hole)

- Must be validated by user
- ASIC MSL 1 level.