

AUTOMOTIVE CURRENT TRANSDUCERS OPEN LOOP TECHNOLOGY

HSNBV 800-R01

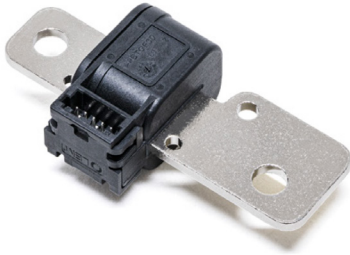

Introduction

The HSNBV series is for the electronic measurement of DC, AC or pulsed currents in high power and low voltage automotive applications with galvanic separation between the primary circuit (high power) and the secondary circuit (electronic circuit). The HSNBV series gives you the choice of having different current measuring ranges in the same housing.

Features

- Ratiometric transducer
- Open Loop transducer using the Hall effect
- Low voltage application
- Unipolar +5 V DC power supply
- Maximum RMS primary admissible current: defined by busbar to have $T < +150\text{ }^{\circ}\text{C}$
- Operating temperature range: $-40\text{ }^{\circ}\text{C} < T < 125\text{ }^{\circ}\text{C}$
- Output voltage: full ratio-metric (in sensitivity and offset).

Special feature

- Special busbar shape.

Advantages

- Excellent accuracy
- Very good linearity
- Very low thermal offset drift
- Very low thermal sensitivity drift
- Galvanic separation
- Non intrusive solution.

Part numbering

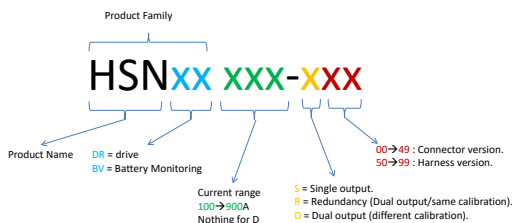

Automotive application

- Battery Management
- EV, Hybrid and utility vehicles
- 48 V battery.

Principle of HSNBV Family

The open loop transducers uses a Hall effect integrated circuit. The magnetic flux density B , contributing to the rise of the Hall voltage, is generated by the primary current I_p to be measured. The current to be measured I_p is supplied by a current source i.e. battery or generator (Figure 1). Within the linear region of the hysteresis cycle, B is proportional to:

$$B(I_p) = a \times I_p$$

The Hall voltage is thus expressed by:

$$U_{Hall} = (c_{Hall} / d) \times I_{Hall} \times a \times I_p$$

Except for I_p , all terms of this equation are constant. Therefore:

$$U_{Hall} = b \times I_p$$

a constant

b constant

c_{Hall} Hall coefficient

d thickness of the Hall plate

I_{Hall} current across the Hall plates

The measurement signal U_{Hall} amplified to supply the user output voltage or current.

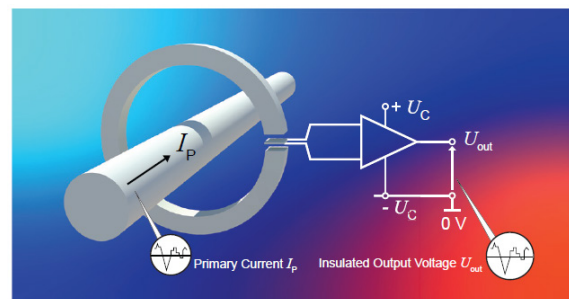
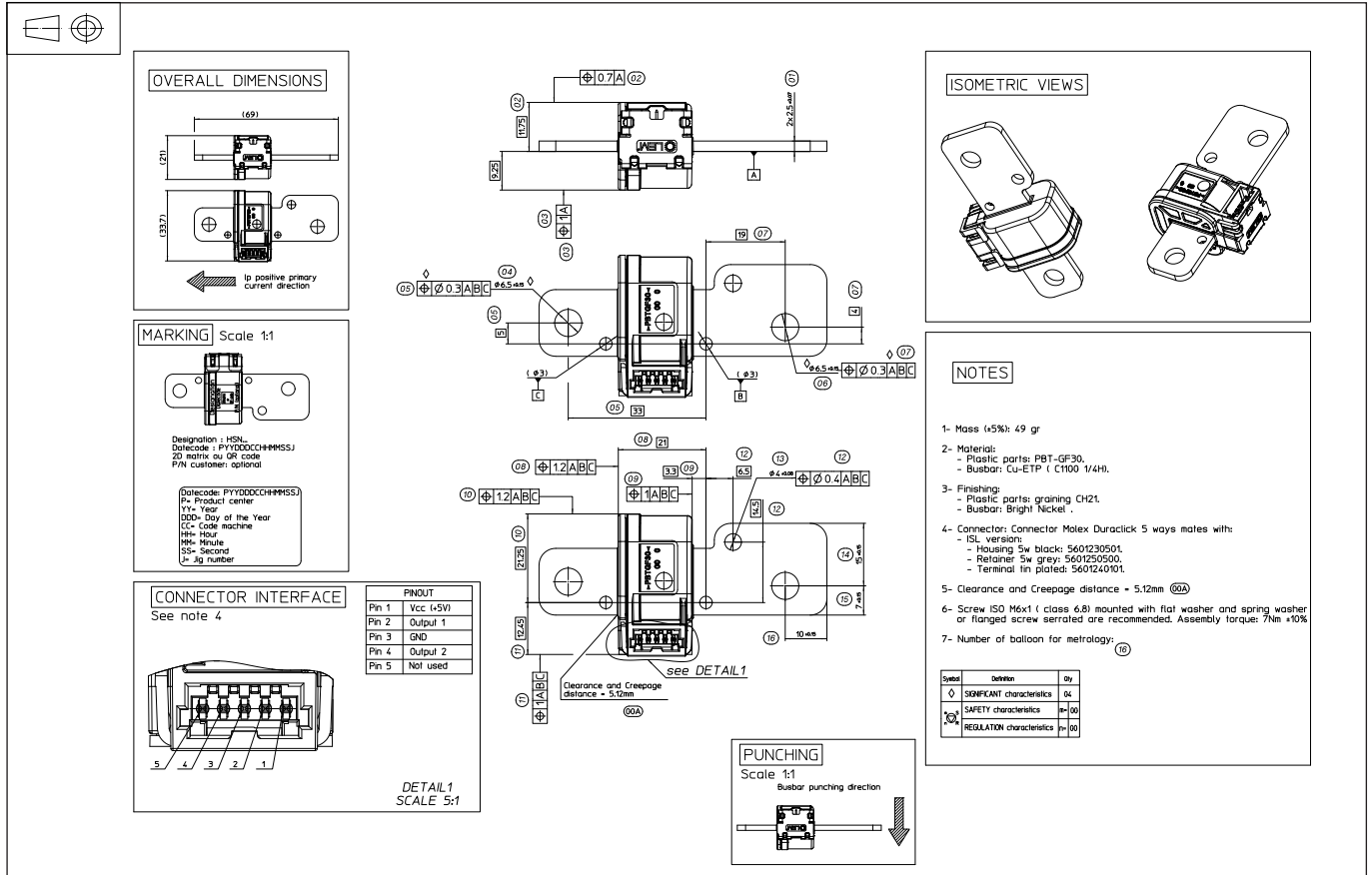

Fig. 1: Principle of the open loop transducer

Dimensions (in mm)



Mechanical characteristics

- Plastic case PBT GF 30
- Magnetic core FeSi alloy
- Busbar Copper
- Mass 49 g ± 5 %
- Pins Brass tin plated
- IP level IP × 2

Mounting recommendation

- Mating connector: Molex duraclik 5 pin:
 - ISL version
 - Housing 5 pin black: 5601230501
 - Retainer 5 pin grey: 5601250500
 - Terminal tin plated: 5601240101
- Assembly torque: see notes on drawing.

Screw mounted with flat washer and spring washer or flanged screw serrated are recommended.

Remark

- $U_{out} > U_0$ when I_p flows in the positive direction (see arrow on drawing).

Electronic schematic

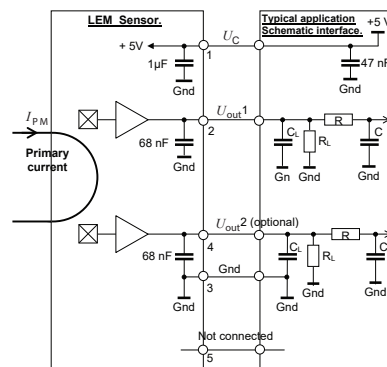

$C_L < 100$ nF EMC protection (optional)
RC Low pass filter (optional)

On board diagnostic

$R_L > 10$ KΩ. Resistor for signal line diagnostic (optional)

U_{out}	Diagnostic
Open circuit	$U_{IN} \leq 0.15$ V
Short GND	$U_{IN} \leq 0.15$ V

Parameter	Symbol	Unit	Specification			Conditions
			Min	Typical	Max	
Maximum supply voltage	U_C	V	-14		14	
Insulation resistance	R_{INS}	MΩ	500			500 V DC, ISO 16750-2
Maximum output voltage	U_{out}	V	-14		14	U_{out} Reverse / Forward voltage
Maximum output current	I_{out}	mA	-10		10	Continuous
Ambient storage temperature	T_{Ast}	°C	-40		125	
Electrostatic discharge voltage (HBM)	$U_{ESD HBM}$	kV			8	IEC 61000-4-2 / ISO 10605
Maximum admissible vibration (random RMS)	γ	m·s ⁻²				see profile on page 7/8
RMS voltage for AC insulation test	U_d	kV			2.5	50 Hz, 1 min; IEC 60664 part1
Creepage distance	d_{Cp}	mm		5.12		
Clearance	d_{Cl}	mm		5.12		
Comparative tracking index	CTI			PLC0		≥ 600 V

Operating common characteristics in nominal range (I_{PN})

Parameter	Symbol	Unit	Specification			Conditions
			Min	Typical	Max	
Electrical Data						
Supply voltage	U_C	V	4.75	5	5.25	
Ambient operating temperature	T_A	°C	-40		125	
Output voltage	U_{out}	V	$U_{out} = (U_C / 5) \times (U_o + S \times I_p)$			
Electrical Data						
Primary current, measuring range (output 1)	I_{PM1}	A	-800		800	
Sensitivity (output 1)	$S1$	mV/A		2.5		@ $T_A = 25$ °C
Offset voltage (output 1)	U_o1	V		2.5		@ $U_C = 5$ V DC
Primary current, measuring range (output 2)	I_{PM2}	A	-800		800	
Sensitivity (output 2)	$S2$	mV/A		2.5		@ $T_A = 25$ °C
Offset voltage (output 2)	U_o2	V		2.5		@ $U_C = 5$ V DC
Output resolution		mV		1.25		
Output clamping high voltage	U_{SZ}	V	4.70	4.75	4.80	@ $U_C = 5$ V, @ -40 °C < T < 125 °C
Output clamping low voltage	U_{SZ}	V	0.20	0.25	0.30	@ $U_C = 5$ V, @ -40 °C < T < 125 °C
Current consumption	I_C	mA		15	20	@ $T_A = 25$ °C, @ $U_C = 5$ V
Load resistance	R_L	kΩ	10			
Output internal resistance	R_{out}	Ω		1	10	@ $T_A = 25$ °C
Performance Data						
Ratiometricity error	ϵ_r	%		±0.3		@ $T_A = 25$ °C
Sensitivity error	ϵ_S	%		±1		@ $T_A = 25$ °C, @ $U_C = 5$ V
Electrical offset voltage	U_{OE}	mV		±4.0		@ $T_A = 25$ °C, @ $U_C = 5$ V
Magnetic offset voltage	U_{OM}	mV		±2		@ $U_C = 5$ V, @ $T_A = 25$ °C
Linearity error	ϵ_L	%		±0.5		% of full scale, method 2
Average temperature coefficient of U_{OE}	TCU_{OEAV}	mV/°K	-0.1	±0.04	0.1	@ $U_C = 5$ V
Average temperature coefficient of S	TCS_{AV}	%/°K	-0.03	±0.01	0.03	
Delay time to 70 % of the final output value for I_{PN} step	t_{D70}	ms			10	
Frequency bandwidth	BW	Hz		1100		@ -3 dB
Peak-to-peak noise voltage	$U_{no pp}$	mV			10	DC to 1 MHz
RMS noise voltage	U_{no}	mV			1.5	DC to 1 MHz
Start up time	t_{start}	ms			1	
Settling time	t_s	ms			10	

Total error (mV)

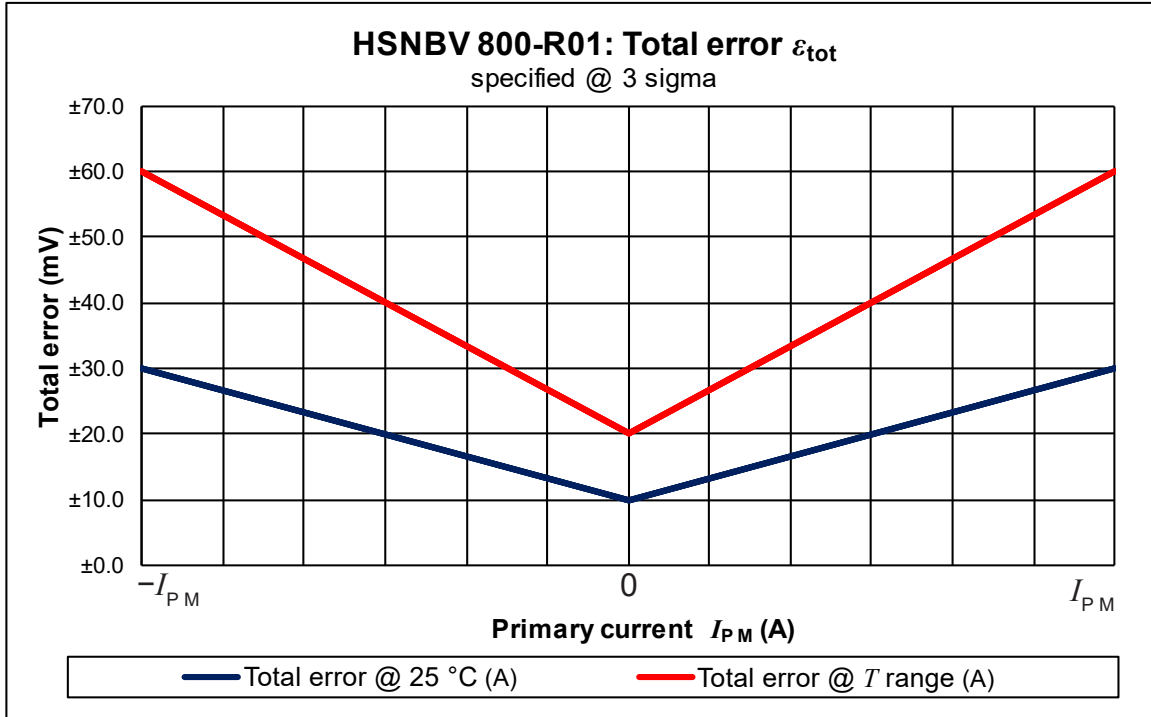

I_P (A)	25 °C initial	T °C range initial	25 °C after reliability	T °C after reliability
$-I_{PM}$	±30 mV	±60 mV	±53 mV	±60 mV
0	±10 mV	±20 mV	±10 mV	±20 mV
I_{PM}	±30 mV	±60 mV	±53 mV	±60 mV

PERFORMANCES PARAMETERS DEFINITIONS

Primary current definition:

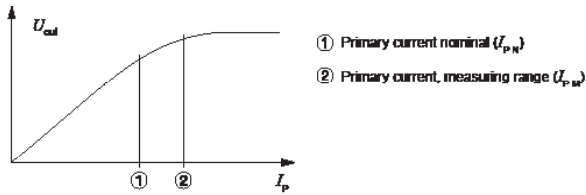

Definition of typical, minimum and maximum values:

Minimum and maximum values for specified limiting and safety conditions have to be understood as such as values shown in "typical" graphs. On the other hand, measured values are part of a statistical distribution that can be specified by an interval with upper and lower limits and a probability for measured values to lie within this interval. Unless otherwise stated (e.g. "100 % tested"), the LEM definition for such intervals designated with "min" and "max" is that the probability for values of samples to lie in this interval is 99.73 %. For a normal (Gaussian) distribution, this corresponds to an interval between -3 sigma and +3 sigma. If "typical" values are not obviously mean or average values, those values are defined to delimit intervals with a probability of 68.27 %, corresponding to an interval between -sigma and +sigma for a normal distribution. Typical, minimum and maximum values are determined during the initial characterization of a product.

Output noise voltage:

The output voltage noise is the result of the noise floor of the Hall elements and the linear amplifier.

Magnetic offset:

The magnetic offset is the consequence of an any current on the primary side. It's defined after a stated excursion of primary current.

Linearity:

The maximum positive or negative discrepancy with a reference straight line $U_{out} = f(I_p)$.
 Unit: linearity (%) expressed with full scale of I_{pN} .

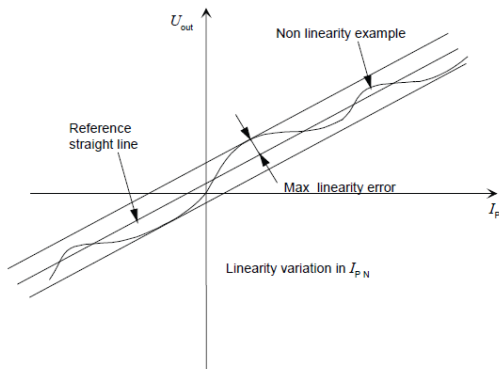

Delay time t_{D70} :

The time between the primary current signal (I_{pN}) and the output signal reach at 70 % of its final value.

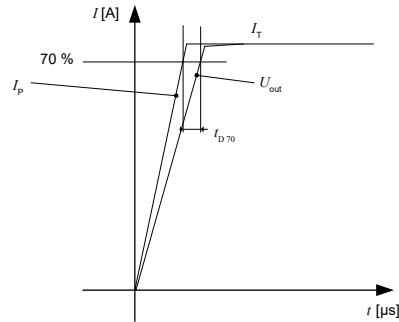

Sensitivity:

The transducer's sensitivity S is the slope of the straight line $U_{out} = f(I_p)$, it must establish the relation:

$$U_{out}(I_p) = U_C / 5 (S \times I_p + U_O)$$

Offset with temperature:

The error of the offset in the operating temperature is the variation of the offset in the temperature considered with the initial offset at 25 °C.

The offset variation I_{OT} is a maximum variation the offset in the temperature range:

$$I_{OT} = I_{OE \max} - I_{OE \min}$$

The offset drift TCI_{OEAV} is the I_{OT} value divided by the temperature range.

Sensitivity with temperature:

The error of the sensitivity in the operating temperature is the relative variation of sensitivity with the temperature considered with the initial offset at 25 °C.

The sensitivity variation S_T is the maximum variation (in ppm or %) of the sensitivity in the temperature range:
 $S_T = (Sensitivity \max - Sensitivity \min) / Sensitivity \text{ at } 25 \text{ } ^\circ C$.

The sensitivity drift TCS_{AV} is the S_T value divided by the temperature range. Deeper and detailed info available is our LEM technical sales offices (www.lem.com).

Offset voltage @ $I_p = 0 A$:

The offset voltage is the output voltage when the primary current is zero. The ideal value of U_O is $U_C / 2$. So, the difference of $U_O - U_C / 2$ is called the total offset voltage error. This offset error can be attributed to the electrical offset (due to the resolution of the ASIC quiescent voltage trimming), the magnetic offset, the thermal drift and the thermal hysteresis. Deeper and detailed info available is our LEM technical sales offices (www.lem.com).

Environmental test specifications:

Refer to LEM GROUP test plan laboratory CO.11.11.515.0 with "Tracking_Test Plan_Auto" sheet.

Environmental test specifications:

Refer to LEM GROUP test plan laboratory CO.11.11.515.0 with "Tracking_Test Plan_Auto" sheet.

Name	Standard	Conditions
ELECTRICAL TESTS		
RMS voltage for AC insulation test	IEC 60664 part 1	2.5 kV AC / 1 min / 50 Hz ($I < 0.1$ mA)
Insulation resistance test	ISO 16750-2 (2010)	500 V DC, time = 60 s $R_{INS} \geq 500$ M Ω Minimum
ENVIRONMENTAL TESTS		
High T °C, High Humidity, Electrical connection	JESD 22-A101 (03/2009)	1000 h +85 °C / 85 % RH $U_C = 5$ V DC, $I_p = 0$ A
Thermal Cycle Test (Simplified profile)	IEC 60068-2-14, Test Nb	$T_{min} -40$ °C, $T_{max} = +125$ °C 1 cycle = 480 min, 30 cycles $U_C = 5$ V (\equiv connected); $I_p = 0$ A
Thermal Shock	ISO-16750-4 § 5.3.2 (04/2010)	1000 cycles 30 min "-40 °C" // 30 min "+85 °C" U_C not connected, $I_p = 0$ A
High T °C Storage	IEC 60068-2-2, Bd (07/2007)	125 °C for 1000 h U_C not connected, $I_p = 0$ A
Low T °C Storage	IEC 60068-2-1, Ad (03/2007)	-40 °C for 240 h U_C not connected, $I_p = 0$ A
Mechanical Shock	ISO-16750-3 § 4.2.2 (12/2012)	50 g / 6 ms Half Sine @ 25 °C 10 shocks of each direction U_C not connected, $I_p = 0$ A
Random vibration test in T °C profile	IEC 60068-2-64	8 h for each axe; $I_p = 0$ A, without monitoring ISO 16750-3, 4.1.2.4, 3 g
Powered Vibration Endurance	CETP:00.00-E-412 § 5.11	Expose the Current Sensor to vibration log sweep at 20 °C while 5 V powered for 6 hours on each primary axis. Vibration class II Output voltage of all DUTs has been monitored
EMC TESTS ES96200 (11.2011)		
Radiated Emission Absorber Lined Shielded Enclosure (ALSE)	CISPR25 (2008) Table9 - class 5	$f = 150$ kHz to 2.5 GHz Criteria A acceptance @ 5 % of 2 V
Radiated Immunity Bulk Current Injection (BCI)	GMW3097 § 3.4.1 (2015)	Level: GMW 3097 (2015) § 3.4.1 Table 13 - Level 1 (100 mA) (ISO11452-4 (2011) Annex E Table E1 Level 2) $f = 1$ MHz to 400 MHz . Criteria A acceptance @ 5 % of 2 V
Radiated Immunity Anechoic chamber	GMW3097 § 3.4.2 (2015)	Level: GMW 3097 (2015) § 3.4.2 Table 14 - Level 2 (100 V/m) $f = 400$ MHz to 1 GHz; Level = 100 V/m (CW, AM 80 %) $f = 0.8$ GHz to 2 GHz; Level = 70 V/m (CW, PM PRR = 217 Hz, PD = 0.57 ms) $f = 1$ GHz to 2 GHz; Level = 70 V/m (CW) Criteria A acceptance @ 5 % of 2 V
ESD Test	GMW3097 § 3.6.3 (2015)	Level: GMW3097 (2015) § 3.6.3.3 Table 28 Contact discharges: ± 4 , 6 kV; Air discharges: ± 8 kV $U_C =$ NO power supply (unconnected). Criteria B

Recommendations for use:**Storage:**

The LEM transducers must be stored in a dry location, within the following ambient room conditions ($< 40\text{ }^{\circ}\text{C}$ and $< 60\% \text{ RH}$). The product should be stored in its original packing. Ensure during storage and transport, the units are not damaged by applying excess weight to the packaging. The transducers must not be stored more than 3 months. Maximal stackup storage of secondary container (pallet) must not exceed 2.

Unpacking:

When unpacking, care must be taken with cutting tools not to damage the transducer.

Handling:

The LEM transducers must be handled with care and not undergo any shocks or falls (fall = scrap). It is recommended to handle the transducer as long as possible inside its original packing (thermoform tray on customer's assembly station). It is forbidden to handle the transducers by their terminals. To avoid problems of ESD, it is recommended not to touch secondary terminals. Any rework operation are forbidden and will conduct part out of LEM warranty.

Installation:

The workshop and the people in contact with the transducers must be ESD protected. Before installing, be sure to check that the transducer corresponds to the required application. Be sure that the air gap between the housing of the transducer and the primary bar is sufficient to avoid damage in case of vibrations.

LEM does not recommend customers to make any maintenance on LEM sensors other wise, it will drive sensors directly out of warranty.

Concerning installation and re-installation , cautiously care need to be taken for taped sensors same for screwed sensors.

Sensors fixed by clips must be scraped after any dismantling from the original locations.