

For the electronic measurement of current: DC, AC, pulsed..., with galvanic separation between the primary and the secondary circuit.



Features

- Bipolar and insulated current measurement
- Current output
- Closed loop (compensated) current transducer using the Hall effect
- Panel mounting.

Special features

- $U_d = 12 \text{ kV}$
- $N_T = 1000$ turns
- $T_A = -40 \text{ °C} \dots +70 \text{ °C}$
- Internal shield connected to external shield
- Connection to secondary circuit on LEMO EGJ.1B.305. CYC connector.

Advantages

- Excellent accuracy
- Very good linearity
- Low temperature drift
- Optimized response time
- Wide frequency bandwidth
- No insertion losses
- High immunity to external interference
- Current overload capability.

Applications

- Single or three phase inverters
- Propulsion and braking choppers
- Propulsion converters
- Auxiliary converters
- High power drives
- Substations.

Standard

- EN 50155: 2021.

Application Domain

- Railway (fixed installations and onboard).

Safety



Caution

If the device is used in a way that is not specified by the manufacturer, the protection provided by the device may be compromised. Always inspect the electronics unit and connecting cable before using this product and do not use it if damaged. Mounting assembly shall guarantee the maximum primary conductor temperature, fulfill clearance and creepage distance, minimize electric and magnetic coupling, and unless otherwise specified can be mounted in any orientation.



Caution, risk of electrical shock

Use caution during installation and use of this product; certain parts of the module can carry hazardous voltages and high currents (e.g. power supply, primary conductor).

Ignoring this warning can lead to injury and and/or cause serious damage.

De-energize all circuits and hazardous live parts before installing the product.

All installations, maintenance, servicing operations and use must be carried out by trained and qualified personnel practicing applicable safety precautions.

This transducer is a build-in device, whose hazardous live parts must be inaccessible after installation.

This transducer must be mounted in a suitable end-enclosure.

Main supply must be able to be disconnected.

Never connect or disconnect the external power supply while the primary circuit is connected to live parts.

Never connect the output to any equipment with a common mode voltage to earth greater than 30 V.

Always wear protective clothing and gloves if hazardous live parts are present in the installation where the measurement is carried out.



ESD susceptibility

The product is susceptible to be damaged from an ESD event and the personnel should be grounded when handling it.

Do not dispose of this product as unsorted municipal waste. Contact a qualified recycler for disposal.

Absolute maximum ratings

Parameter	Symbol	Unit	Value
Maximum supply voltage (working) (-40 ... 70 °C)	$\pm U_{C\max}$	V	± 26.4
Maximum primary conductor temperature	$T_{B\max}$	°C	100

Absolute maximum ratings apply at 25 °C unless otherwise noted.
 Stresses above these ratings may cause permanent damage.
 Exposure to absolute maximum ratings for extended periods may degrade reliability.

Environmental and mechanical characteristics

Parameter	Symbol	Unit	Min	Typ	Max	Comment
Ambient operating temperature	T_A	°C	-40		70	
Ambient storage temperature	$T_{A\text{st}}$	°C	-50		85	
Equipment operating temperature class						EN 50155: OT4
Switch-on extended operating temperature class						EN 50155: ST0
Rapid temperature variation class						EN 50155: H1
Conformal coating type						EN 50155: PC2
Relative humidity	RH	%	20		80	non-condensing
Shock & vibration categorie and class						EN 50155: 1B (EN 61373)
Mass	m	g		6000		
Ingress protection rating				IP40		IEC 60529 (indoor use)
Pollution degree					PD2	Insulation voltage accordingly
Altitude		m			2000 ¹⁾	

RAMS data

Parameter	Symbol	Unit	Min	Typ	Max	Comment
Useful life class						EN 50155: L4

Note: ¹⁾ Insulation coordination at 2000 m.

Insulation coordination

Parameter	Symbol	Unit	≤ Value	Comment
RMS voltage for AC insulation test, 50 Hz, 1 min	U_d	kV	12	Between primary and secondary + test winding + shield
			1	Between secondary and test winding + shield
Impulse withstand voltage 1.2/50 μ s	U_{Ni}	kV	17.7	According to IEC 50124-1
Partial discharge RMS test voltage ($q_m < 10$ pC)	U_t	V	5760	Test carried out with a non insulated bar and completely filling the primary hole. According to IEC 61287-1 (not performed on serial test)
Clearance (pri. - sec.)	d_{Cl}	mm	68	Shortest distance through air
Creepage distance (pri. - sec.)	d_{Cp}	mm	68	Shortest path along device body
Case material	-	-	V0	According to UL 94
Comparative tracking index	CTI		600	Material group I
Application example Rated insulation RMS voltage	U_{Nm}	V	4800	Reinforced insulation according to IEC 62497-1 CAT III, PD2

Electrical data

At $T_A = 25\text{ °C}$ unless otherwise noted (see Min, Max, typ, definition paragraph).

Parameter	Symbol	Unit	Min	Typ	Max	Comment
Primary nominal AC RMS current (continuous)	I_{PNAC}	A	-4000		4000	$f \leq 100\text{ Hz}$
Primary current, measuring range	I_{PM}	A	-6000		6000	With $\pm U_C = \pm 24\text{ V}$ (-12.5%), $T_A = 70\text{ °C}$, $R_M = 1\ \Omega$; for other conditions, see figure 1
Measuring resistance	R_M	Ω	0			see figure 1
Secondary nominal RMS current	I_{SN}	mA	-800		800	
Resistance of secondary winding	R_S	Ω	12.5	12.8	13	@ 25 °C ¹⁾
Number of secondary turns	N_S			5000		
Number of turns (test winding)	N_T			1000		$R_T = 21.4\ \Omega$ @ 25 °C
Maximum test current (test winding)	I_{Tmax}	A			1	@ $-40 \dots 70\text{ °C}$
DC supply voltage ---	U_C	V	± 21	± 24	± 26.4	
DC current consumption ---	I_C	mA	25	$27 + I_S \times N_P / N_S$	29	@ $U_C = \pm 24\text{ V}$, $I_P = 0$, @ 25 °C
Total error	ϵ_{tot}	%			± 0.5	@ 25 °C (@ I_{PN})
					± 0.8	@ $-40 \dots 70\text{ °C}$ (@ I_{PN})
Electrical offset current	I_{OE}	mA			± 0.8	@ 25 °C (@ $I_P = 0$)
Temperature variation of I_{OE}	I_{OT}	mA		± 0.4	± 0.8	referred to 25 °C
Magnetic offset current	I_{OM}	mA		0.2		after $3 \times I_{PN}$ @ 25 °C
Linearity error	ϵ_L	% of I_{PN}			< 0.1	@ 25 °C
					< 0.2	@ $-40\text{ °C} \dots 70\text{ °C}$
RMS noise 1 Hz ... 10 MHz referred to primary	I_{no}	ppm of I_{PN}		90		see figure 4
Delay time to 10 % of the final output value I_{PN} step	t_{D10}	μs		< 1		With $di/dt > 50\text{ A}/\mu\text{s}$ See figure 2
Delay time to 90 % of the final output value I_{PN} step	t_{D90}	μs		< 1		With $di/dt > 50\text{ A}/\mu\text{s}$ See figure 2
Frequency bandwidth (-1 dB)	BW	kHz		10		With $\pm U_C = \pm 24\text{ V}$, $T_A = 25\text{ °C}$, primary return twisted on back side; see figure 5
Frequency bandwidth (-3 dB)			130			

Note: ¹⁾ $R_S(T_A) = R_S \times (1 + 0.004 \times (T_A + \Delta\text{Temp} - 25))$ estimated temperature increase @ I_{PN} is $\Delta\text{Temp} = 15\text{ °C}$.

Definition of typical, minimum and maximum values

Minimum and maximum values for specified limiting and safety conditions have to be understood as such as well as values shown in "typical" graphs.

On the other hand, measured values are part of a statistical distribution that can be specified by an interval with upper and lower limits and a probability for measured values to lie within this interval.

Unless otherwise stated (e.g. "100 % tested"), the LEM definition for such intervals designated with "min" and "max" is that the probability for values of samples to lie in this interval is 99.73 %.

For a normal (Gaussian) distribution, this corresponds to an interval between -3 sigma and +3 sigma. If "typical" values are not obviously mean or average values, those values are defined to delimit intervals with a probability of 68.27 %, corresponding to an interval between -sigma and +sigma for a normal distribution.

Typical, maximal and minimal values are determined during the initial characterization of the product.

Typical performance characteristics

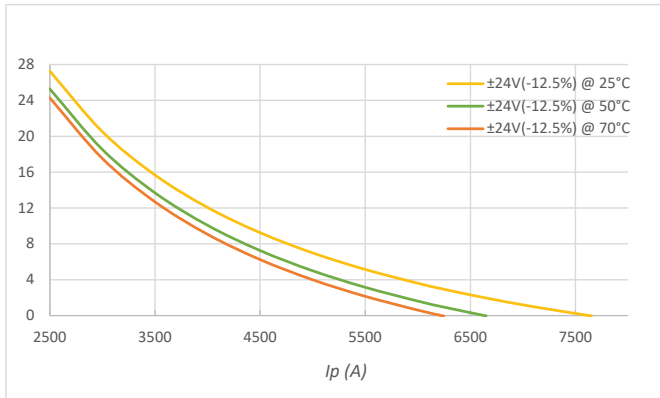

Figure 1: Maximum measuring resistance

$$R_{Mmax} = N_S \times \frac{U_{Cmin} - 0.7V}{I_p} - R_{Smax}$$

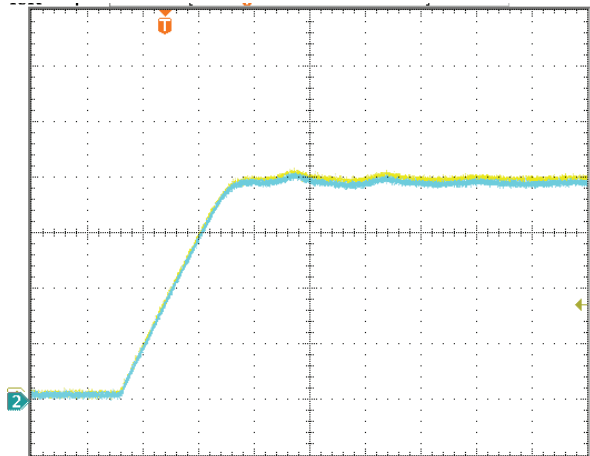

Figure 2: ch1: $I_p = 4000$ A/ch2: $I_s = 0.2$ A/div, di/dt 50 A/μs according to the report CA031109 (test done on LT 4000-T/SP42)

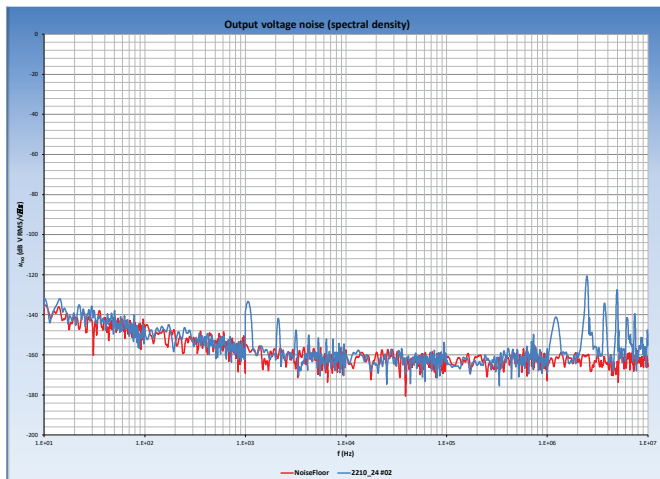

Figure 3: Typical output noise voltage spectral density with $R_M = 1$ Ohm (test done on LT 4000-S/SP35)

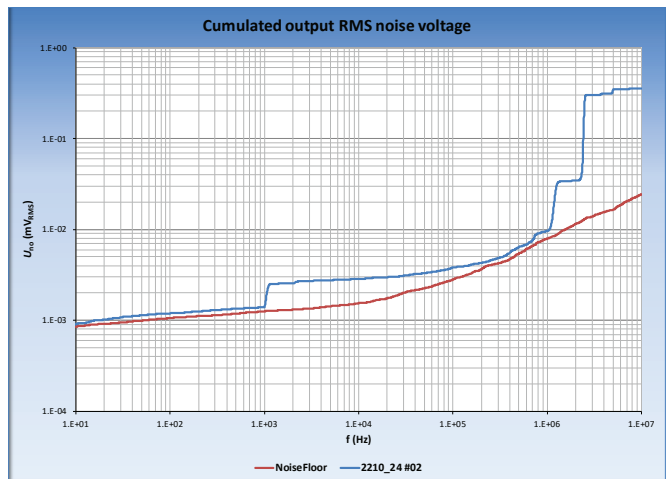

Figure 4: Typical output RMS noise current with $R_M = 1$ Ohm (primary referred) (test done on LT 4000-S/SP35)

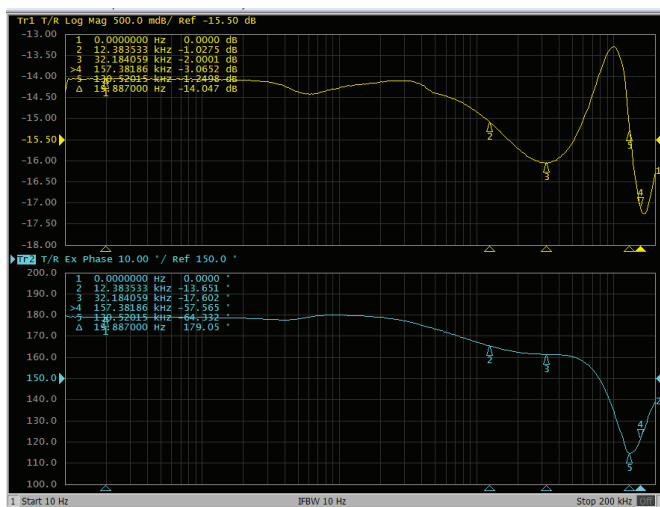

Figure 5: Frequency bandwidth

Terms and definitions

Ampere-turns and amperes

The transducer is sensitive to the primary current linkage θ_p (also called ampere-turns).

$$\theta_p = N_p \cdot I_p$$

Where N_p is the number of primary turn.

Caution: As most applications will use the transducer with only one single primary turn ($N_p = 1$), much of this datasheet is written in terms of primary current instead of current linkages. However, the ampere-turns (A) unit is used to emphasis that current linkages are intended and applicable.

Simplified transducer model

The static model of the transducer with current output at temperature T_A is:

$$I_s = \theta_p \cdot (1 + \varepsilon)$$

In which (referred to primary):

$$\varepsilon \cdot \theta_p = I_{OE} + I_{OT} + \varepsilon_L(\theta_{Pmax}) \cdot \theta_{Pmax} + I_{OM}$$

- $\theta_p = N_p \cdot I_p$: primary current linkage (A)
- θ_{Pmax} : maximum primary current linkage applied to the transducer
- I_s : secondary current (A)
- T_A : ambient operating temperature (°C)
- I_{OE} : electrical offset current (A)
- I_{OM} : magnetic offset current (A)
- I_{OT} : temperature variation of I_{OE} (A)
- $\varepsilon_L(\theta_{Pmax})$: linearity error for θ_{Pmax}

This model is valid for primary ampere-turns θ_p between $-\theta_{Pmax}$ and $+\theta_{Pmax}$ only.

This is the absolute maximum error. As all errors are independent, a more realistic way to calculate the error would be to use the following formula:

Total error referred to primary

The total error ε_{tot} is the error at $\pm I_{PN}$, relative to the rated value I_{PN} .

It includes all errors mentioned above

$$\varepsilon = \sqrt{\sum_{i=1}^N \varepsilon_i^2}$$

- the electrical offset I_{OE}
- the magnetic offset I_{OM}
- the linearity error ε_L (to I_{PN}).

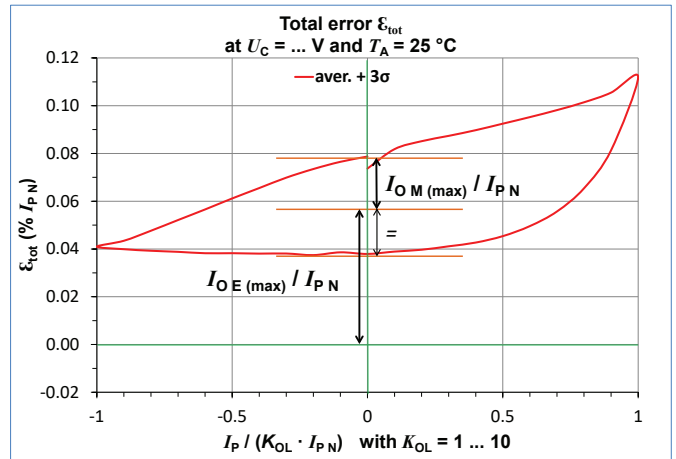

Figure 6: Total error ε_{tot}

Electrical offset referred to primary

Using the current cycle shown in figure 6 the electrical offset current I_{OE} is the residual output referred to primary when the input current is zero.

$$I_{OE} = \frac{I_{P(3)} + I_{P(5)}}{2}$$

The temperature variation I_{OT} of the electrical offset current I_{OE} is the variation of the electrical offset from 25 °C to the considered temperature.

$$I_{OT}(T) = U_{OE}(T) - U_{OE}(25 \text{ °C})$$

Magnetic offset referred to primary

The magnetic offset current I_{OM} is the consequence of a current on the primary side ("memory effect" of the transducer's ferro-magnetic parts). It is measured using the following primary current cycle. I_{OM} depends on the current value $I_p \geq I_{PN}$. K_{OL} : Overload factor

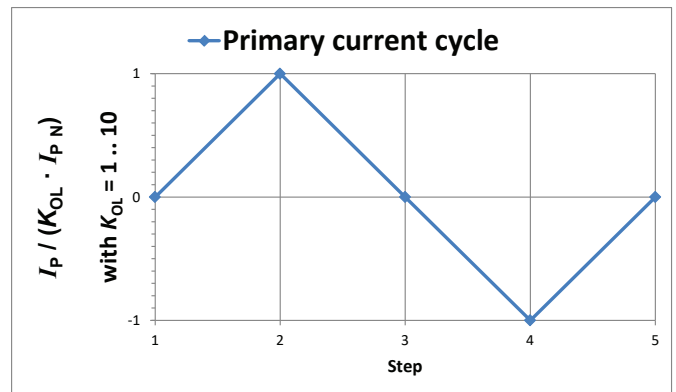

Figure 7: Current cycle used to measure magnetic and electrical offset (transducer supplied)

$$I_{OM} = \frac{I_{P(3)} - I_{P(5)}}{2}$$

Sensitivity and linearity

To measure sensitivity and linearity, the primary current (DC) is cycled from 0 to I_p , then to $-I_p$ and back to 0 (equally spaced $I_p/10$ steps). The linearity error ϵ_L is the maximum positive or negative difference between the measured points and the linear regression line, expressed in % of I_{PN} .

Delay times

The delay time t_{D10} @ 10 % and the delay time t_{D90} @ 90 % with respect to the primary are shown in the next figure. Both slightly depend on the primary current di/dt . They are measured at nominal current.

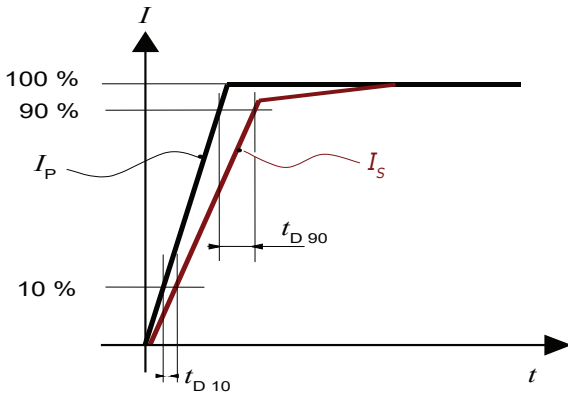

Figure 8: t_{D10} (delay time @ 10 %) and t_{D90} (delay time @ 90 %).

Specifics performance characterized

Frequency response of LT 4000-S/SP35 in the bandwidth 20 Hz < f < 200 Hz						
	Line current of 0 A		Line current of 20 A		Line current of 400 A	
AC current (20 ... 200 HZ)	Amplitude error (%)	Phase error (°)	Amplitude error (%)	Phase error (°)	Amplitude error (%)	Phase error (°)
1 A (at 50 Hz)	±20.6	-15	±6.7	-3.6	±6.7	-3.6
2 A (at 50 Hz)	±11.9	-7	±4.1	-3	±4.1	-3

Amplitude error: in % of the measured signal

Phase error: in degrees with respect to the measured signal.

Maximum amplitude and phase errors for small AC currents added to different DC line currents.

Dimensions (in mm)

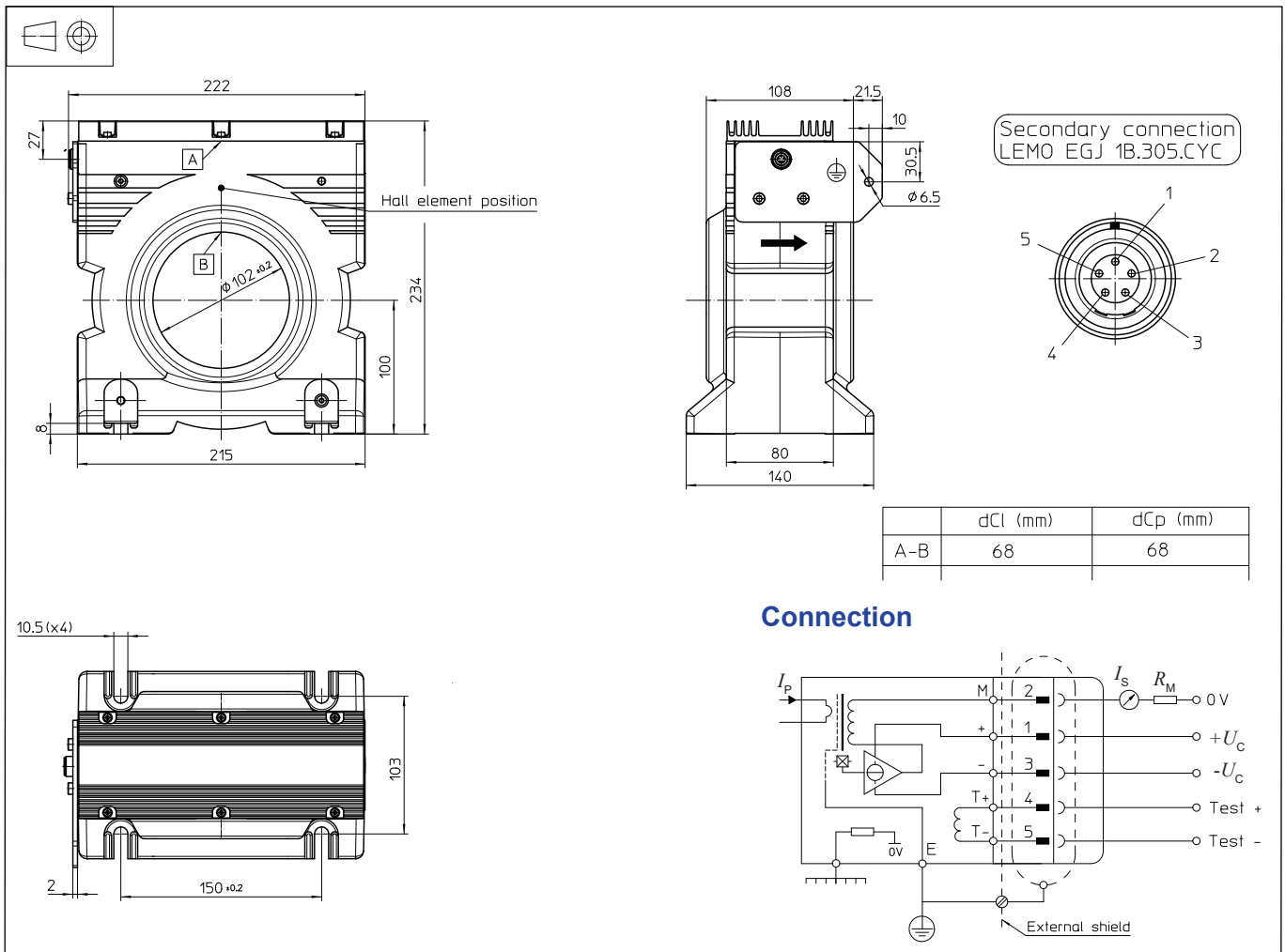

Mechanical characteristics

- General tolerance ± 1 mm
- Transducer fastening 4 notches $\varnothing 10.5$ mm
4 \times M10 steel screws
- Recommended fastening torque 11.5 N·m
- Connection of shield 1 hole $\varnothing 6.5$ mm
- Connection of primary $\varnothing 102$ mm
- Connection of secondary LEMO EGJ.1B.305.CYC connector

Remarks

- I_s is positive when I_p flows in the direction of arrow.
- The secondary cables also have to be routed together all the way.
- Dynamics performances "delay time" are best with a single bar completely filling the primary hole.
- Installation of the transducer must be done, unless otherwise specified on the datasheet, according to LEM Transducer Generic Mounting Rules. Please refer to LEM document N°ANE120504 available on our Web site: <https://www.lem.com/en/file/3137/download/>